

NEW



ELECTRIC MINI EXCAVATOR | 19C-IE

Transport weight: 1787-1827kg Zero Emissions. Lithium-ion Technology.







CHOOSE ZERO EMISSIONS

The new 19C-IE is the industry's first fully electric mini excavator. It lets you do a full day's work on a single charge, giving you access to a whole new world of possibilities.

JCB is leading the way in clean technology and reducing harmful emissions, especially in urban, air quality sensitive environments and enclosed spaces. That's why JCB are introducing E-TEC, a new generation of electric products with zero emissions at point of use that don't compromise on performance. The new 19C-IE is the first of the electric generation.

E-TEC

CHOOSE A FULL DAY'S WORK.

THE NEW I9C-IE GIVES YOU THE FREEDOM TO WORK ANYWHERE, ANYTIME WITH QUICK CHARGING AND ENOUGH BATTERY LIFE TO LET YOU WORK FOR A FULL DAY ON A SINGLE CHARGE. WITH 3 CHARGING OPTIONS, YOU CAN GET TO WORK WHEN AND WHERE IT SUITS YOU.

The standard 3 battery pack offering gives 4 hours of continuous use; equivalent to a full day's typical work for the machine. The optional 4 battery pack offering extends this to 5 hours of typical work.

You can keep a check of the battery status via a gauge on the instrument panel.

1 With three charging options: 110V, 230V and 415V, the I9C-IE is so versatile in getting the machine working straight away in the right place and in a timely manner that is convenient for you.

With a low operating weight and a combined 10 tie down points, the I9C-IE can be easily transported to wherever needed.

2 Electro proportional control as standard enables finer control through an auxiliary thumb switch to allow for precision control of attachments. For instance, on utility jobs; the machine can operate in a low mode whilst maintaining the same tearout forces as in high mode.



3 The new hydraulic system allows for smooth, accurate operation for even the less experienced operator; increasing productivity.

4 Bucket rotation is a huge 201°, offering great spoil retention for use in truck loading for example, providing total freedom in multi-sector work. Dipper lengths are 950mm, 1100mm and 1344mm.

5 Simple in design, the canopy offers 270° visibility, perfect when working in confined areas with the optional poly-screen for protection when breaking.

6 Graphite impregnated bushes with industry's lowest greasing intervals of 500 hours, means no need for daily greasing, freeing up extra time.

7 The dozer geometry allows the blade to become free of material build up. With easy to use swing out dozer wing extensions, there's no need for any tools during operation.



CHOOSE **ECONOMICAL.**

THE NEW I9C-IE REDUCES SERVICING TIME AND COSTS. NO EXTRA MANPOWER IS NEEDED TO ASSIST WITH MONITORING AND THERE IS NO NEED FOR EMISSIONS EXTRACTION SAVING ON WAGES AND EQUIPMENT. AND OF COURSE, ELECTRICITY IS A LOT CHEAPER THAN FOSSIL FUEL. THERE ARE NO ENGINE LIQUIDS TO CHECK, SO DAILY CHECKS ARE REDUCED, SAVING YOU TIME AS WELL AS MONEY.



The batteries are completely maintenance free, minimising daily checks.

1 Standard two speed tracking is operated by an easy-to-use button on the dozer making working life just that little bit easier and in turn, much more time effective.

2 Our hydraulic system allows you to travel in a straight line at the same time as selecting excavator functions, increasing productivity.

3 As the machine is 6 decibels (external noise) quieter than the diesel variant, the operator can communicate much more effectively with colleagues, getting the job done quicker.



4 Auto idle makes working efficiently simple by reducing the revs when idle for a set amount of time and therefore utilises the battery in the most effective way.

5 Reduced minimum front swing radius for a compact machine that can tuck up to work in the tightest of conditions without compromise to load over height.

A two-year warranty on the lithium-ion batteries makes life simple and offers peace of mind.

Quicker turnaround times thanks to no daily greasing, easy access for maintenance and faster cleaning due to the sloping undercarriage track legs.

By removing the engine and associated items, there is a reduction in the number of serviceable parts required at 500 hours, 1000 hours and 2000 hours, saving you time and money.



The 19C-1E comes as standard with the addition of the new auto kick-up feature. This feature skilfully distributes power to preserve battery life whilst still allowing for a faster tracking speed.

CHOOSE SAFE.

AS WORKING CONDITIONS BECOME MORE AND MORE RESTRICTED, SAFETY BECOMES MORE AND MORE IMPORTANT. WITH NO TRAILING TETHERS, ZERO EMISSIONS, LOW NOISE LEVELS AND JCB'S 2GO SAFETY SYSTEM, THE NEW I9C-IE PROVIDES THE PEACE OF MIND YOU NEED TO WORK SAFELY AND EFFICIENTLY.

The I9C-IE incorporates instrumentation carried over from the New Generation range, including an integrated membrane switch immobiliser pad for increased safety.

The canopy is ROPS, TOPS and FOGS rated for full safety compliance.

- 1 For extra safety, all services are isolated when the control pod is raised.
- 2 There is a single point lockable electrical service disconnect switch.

- 3 The I9C-IE is a machine that operates completely free of an umbilical cord, increasing safety and reducing the cost of a banksman.

Safe pre-start checks allow you to check hydraulic oil levels from outside of the machine without having to turn the machine on.

- 4 Right hand positioned panel with easy button functions, easy to read indicators and warnings allow the operator to always be aware of the machines status as well as potential risks.

- 5 180° opening service door to access all major electrical components for service and maintenance points with a separate daily checks door, accessing the electrical isolator.

- 6 Lift overload audible warning system on the I9C-IE ensures maximum stability and safety when working efficiently.

- 7 Optional operator presence and seat belt isolation switches for increased on site safety.



With no exposure to fumes, as well as zero emissions at point of use, the I9C-IE makes the whole job cleaner with minimal impact to operators and banksmen.

Automatic slew lock is a huge benefit, ensuring the highest safety measures are met whilst on site and in transport.

8 JCB's unique 2GO system gives an additional layer of safety, meaning all controls are fully isolated unless the 2GO button is activated. There is a Thatcham approved immobiliser*, minimising the possibility of an unauthorised start.

* Region specific.

9 Spacious operator station with a large viewing area combine to give excellent all-round visibility for increased on site safety.

10 Optional factory-fitted manual or hydraulic quick hitch allows the operator to switch between attachments quickly and safely.



8



9

CHOOSE QUIET.

THE NEW I9C-IE HAS LOW NOISE LEVELS, MAKING IT IDEAL FOR URBAN AREAS AND INDOOR WORKING, WHERE IT ALSO ALLOWS BETTER COMMUNICATION WITH CO-WORKERS, GETTING THE JOB DONE QUICKER. IT ALSO MEANS THERE ARE NO RESTRICTIONS ON HOURS OF OPERATION.

1 With noise at the operator station reduced by a huge 10 dB (versus the diesel), the operator has the perfect operating environment, and can easily communicate with colleagues in close proximity.

External noise is also reduced by 6 dB (versus the diesel), making the I9C-IE ideal for noise sensitive environments.

2 Visually, the I9C-IE is fitted with a blue light indicator to show the machine is running.

3 The I9C-IE machine is perfect for noise and air quality sensitive environments as it allows for 'out-of-hours' working, helping to maximise time on site and speed up the job.

Three single flanged bottom rollers allied with short pitch tracks ensures a quiet, smooth ride.





CHOOSE TOUGH.

THE NEW JCB I9C-IE ELECTRIC MINI EXCAVATOR HAS BEEN DESIGNED AND BUILT TO WITHSTAND THE TOUGHEST OF JOB SITES. WITH LONG-LASTING COMPONENTS AND EASY, COST-EFFECTIVE REPAIRS, IT PROVIDES MINIMUM DOWNTIME AND MAXIMUM PROFITS.

All hydraulic components are assembled within a hydraulic clean room and go through multi-stage hot tests and oil detection processes to ensure reliability.

Improved dig end pins with ARCO coating protect pins against corrosion, helping towards reduced cost of ownership.

1 Hoses are routed through the boom, dipper and kingpost for ultimate durability. The I9C-IE uses O-ring faced seal hydraulics which provides excellent sealing capabilities.

The electrical circuit has gone through an extensive testing and development programme to maximise longevity and efficiency of every detail, right down to the heavy duty cables.

2 The standard heavy-duty kingpost optimises service life and lowers the cost of ownership due to the durable re-bushable pivots.

The strong, durable H frame undercarriage provides rigid support with an open design allowing spoil to fall readily preventing excessive componentry wear.

3 Reassurance through proven automotive technology and state-of-the-art manufacturing processes to achieve ultimate build quality, reliability, durability, service life and machine uptime.



2



100% steel bodywork that withstands knocks and is cost effective to repair.



1



3



The top mounted boom ram reduces the risk of damage on site, for instance when working in confined spaces.

For ultimate rigidity, the extending undercarriage beams are constructed from 25mm solid steel plate.

CHOOSE PEACE OF MIND.

WITH NEW INNOVATION COMES NEW QUESTIONS. WE'VE ANTICIPATED THE MOST FREQUENTLY ASKED, AND ANSWERED THEM HERE. WE HOPE THEY'LL GIVE YOU THE REASSURANCE YOU NEED. IF YOU HAVE ANY OTHERS, PLEASE TALK TO YOUR LOCAL DEALER.

The machine shares the same structure, canopy, dig end, hydraulics and controls as the diesel model and performs in exactly the same way. The only change is that the power pack changes from a diesel to electric.

The 3 battery pack will last for the equivalent of a full day's work, subject to the type of job.

12 hours charge time from a 110V supply or 8 hours charge time from a 230V supply on the standard 3 battery pack offering.

Fast Charge option, offering charging times of less than 2 hours on the standard 3 battery pack machine from a 415V supply.

The batteries cannot be easily stolen as they sit deep within the structure of the machine. They would take several hours to remove.

The warranty on the machine and batteries is 2 years.

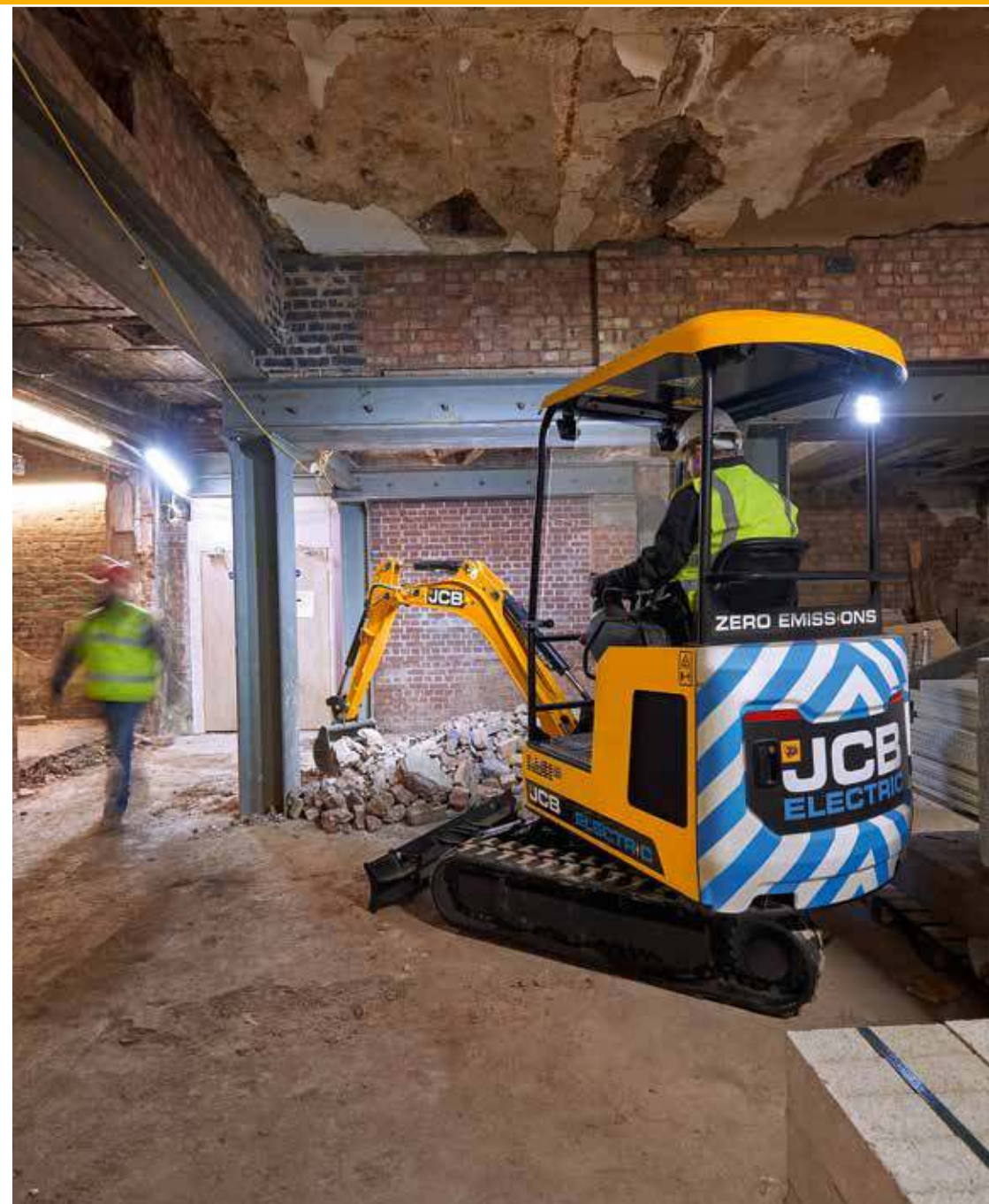

CHOOSE SMART.

LIVELINK IS AN INNOVATIVE SOFTWARE SYSTEM THAT LETS YOU MANAGE JCB MACHINES REMOTELY – ONLINE, BY EMAIL OR BY MOBILE PHONE. ACCESS EVERYTHING FROM MACHINE ALERTS TO HISTORY INFORMATION, WITH ALL DATA STORED AT A SECURE CENTRE.

Productivity and cost benefits

By providing information like machine location, Livelink can help improve efficiency and perhaps even reduce insurance costs. By providing information like machine location, Livelink can help improve efficiency and perhaps even reduce insurance. Livelink comes as standard on the 19C-IE.



Maintenance benefits

Manage machine maintenance easily – accurate hours monitoring and service alerts improve maintenance planning, while real-time location data helps you manage your fleet. Critical machine alerts and maintenance history records are also available.



Security benefits

Livelink's real-time geofencing alerts tell you when machines move out of predetermined zones, and real-time curfew alerts inform you of unauthorised usage. Further benefits include real-time location information, advanced ECU matching (pairs Livelink with the immobiliser or ECU), and 14 individual pin code (to remotely authorise usage – perfect for plant hire).



CHOOSE GLOBAL EXPERTISE.

JCB'S WORLDWIDE CUSTOMER SUPPORT IS FIRST CLASS. WHATEVER YOU NEED AND WHEREVER YOU ARE, WE'LL BE AVAILABLE QUICKLY AND EFFICIENTLY TO HELP MAKE SURE YOUR MACHINERY IS PERFORMING TO ITS FULL POTENTIAL.



1

1 Our Technical Support Service provides instant access to factory expertise, day or night, while our Finance and Insurance teams are always on hand to provide fast, flexible, competitive quotes.

2 The global network of JCB Parts Centres is another model of efficiency; with 18 regional bases, we can deliver around 95% of all parts anywhere in the world within 24 hours. Our genuine JCB parts are designed to work in perfect harmony with your machine for optimum performance and productivity.



2

3 JCB offers comprehensive extended warranties as well as service-only or repair and maintenance contracts. Irrespective of what you opt for, our Maintenance teams around the world charge competitive labour rates, and offer non-obligation quotations as well as fast, efficient insurance repair work.



3

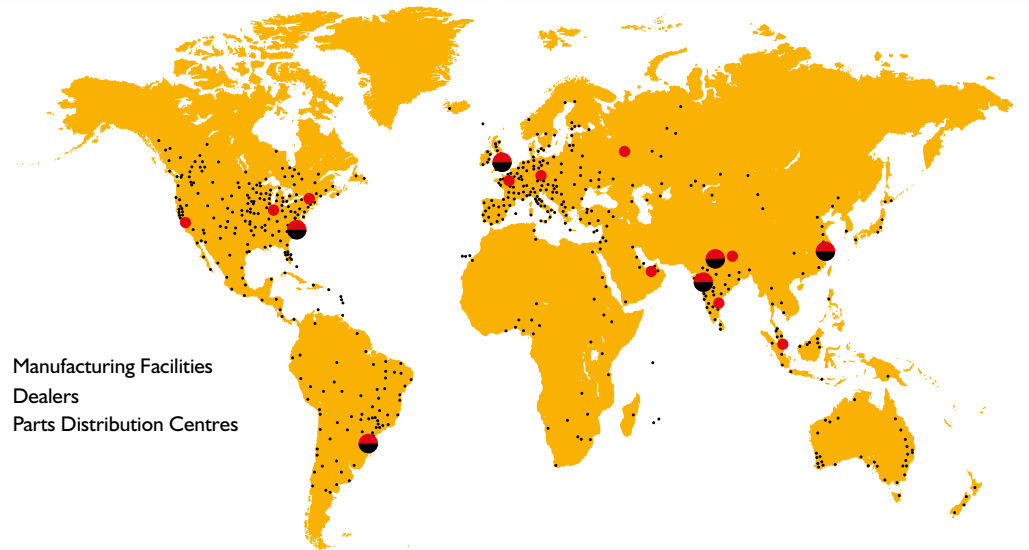

Note: JCB LIVELINK and JCB extended warranty packages may not be available in your region, so please check with your local dealer.

STATIC DIMENSIONS

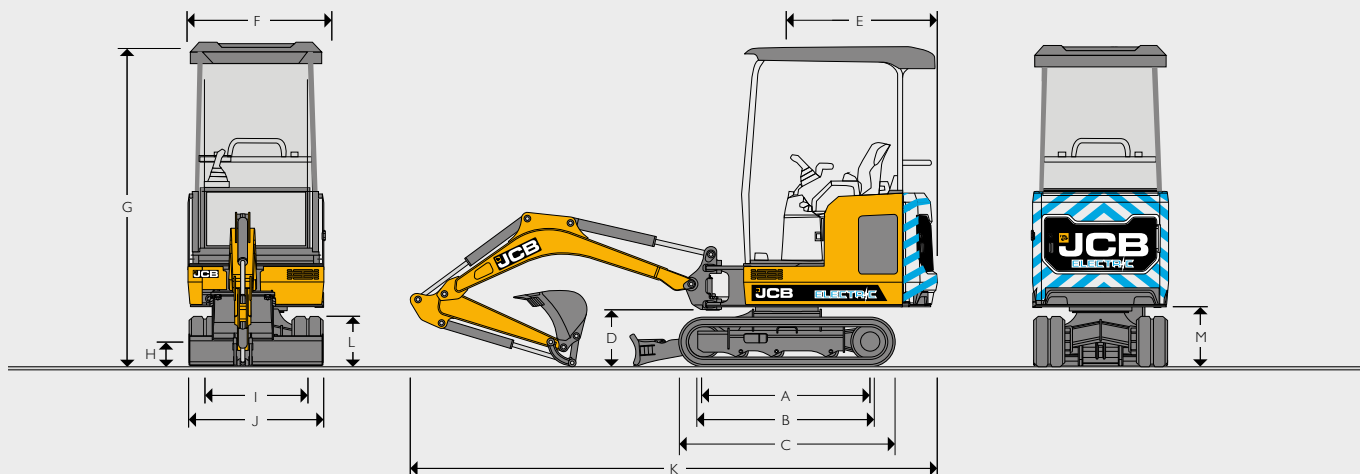

STATIC DIMENSIONS

A	Sprocket idler centres	mm	1218
B	Track length on ground	mm	1220
C	Undercarriage overall length – rubber	mm	1578
	Undercarriage overall length – steel	mm	1578
D	Kingpost clearance	mm	409
E	Tailswing radius	mm	1103
F	Overall width of superstructure	mm	996
G	Height over canopy	mm	2345
H	Ground clearance	mm	162
I	Track gauge – retracted/extended	mm	750-1110
J	Width over tracks / rubber / steel – retracted	mm	980
	Width over tracks / rubber / steel – extended	mm	1330
K	Transport length	mm	3860 – 3815
L	Track height	mm	367
M	Counterweight clearance	mm	434

POWER SOURCE

Battery Type	Manganese laminated Lithium-ion
Gross Capacity	14.8 kWh (3 pack) / 19.8 kWh (4 pack option)
System Voltage	48V
Indicative Run Time	4 hours (3 pack), 5 hours (4 pack), based upon typical duty cycle.
Zero Emissions at point of use	

CHARGING

On-board charger allowing direct connection to AC mains power supply

Indicative Charge Time 0-100% for a 3 battery pack machine, subject to environmental conditions

On-board @ 110V – 12 hrs

On-board @ 230V – 8 hrs

Off-board fast charge (optional) @ 415V

2 – 2.5 hrs

Charging cable plug type

16A 110V (Yellow)

16A 230V (Blue)

add 16A 415V (Red)

MOTOR

Motor Type	3 Phase AC Permanent Magnet
Motor Power	7kW continuous, 20kW peak
Operating Modes	L: 1200rpm G: 1600rpm H: 1800rpm

UNDERCARRIAGE

	Retractable
No. of bottom rollers	3
Track width rubber	mm 230
Travel speed – low	kph 2.4
Travel speed – high	kph 4.1
Tractive effort	kN 13.2

HYDRAULIC SYSTEM

Pump	cc	18
Nominal output @ max rpm	lpm	42
Excavator/track main relief pressure	bar	235
Slew main relief pressure	bar	167
Auxiliary hydraulic pressure (Aux 1)	bar	200
Auxiliary hydraulic pressure (Aux 2)	bar	200
Auxiliary hydraulic flow (Aux 1)	lpm	32
Auxiliary hydraulic flow (Aux 2)	lpm	32
Hydraulic pump		Piston

WEIGHTS

Operating weight*	kg	1862-1902
Long dozer	kg	9
Mechanical quickhitch	kg	14
Hydraulic quickhitch (without hoses)	kg	24
Gravemaster dipper	kg	5
Shipping weight**	kg	1769
Ground bearing pressure (rubber tracks)	kg/cm ²	0.36
Transport weight (operator weight - 75kg)	kg	1787-1827

*Operator weight to ISO 6016 including canopy, rubber tracks, 950 dipper, 1100 dipper, 300mm bucket, 75kg operator. **Shipping weight to ISO 6016 is mass of the base machine without operator.

SERVICE CAPACITIES

Hydraulic system	ltr	28
Hydraulic tank	ltr	15

OPERATOR ENVIRONMENT

Canopy height	mm	1364
Canopy length	mm	1427
Canopy width	mm	978

DOZER

Dozer length (STD) centre of boss	mm	787
Max. height above ground	mm	239
Dig depth below ground	mm	225
Approach angle	degrees	25.3
Width (without wings)	mm	980
Width (with wings)	mm	1340
Height	mm	234

WORKING RANGE

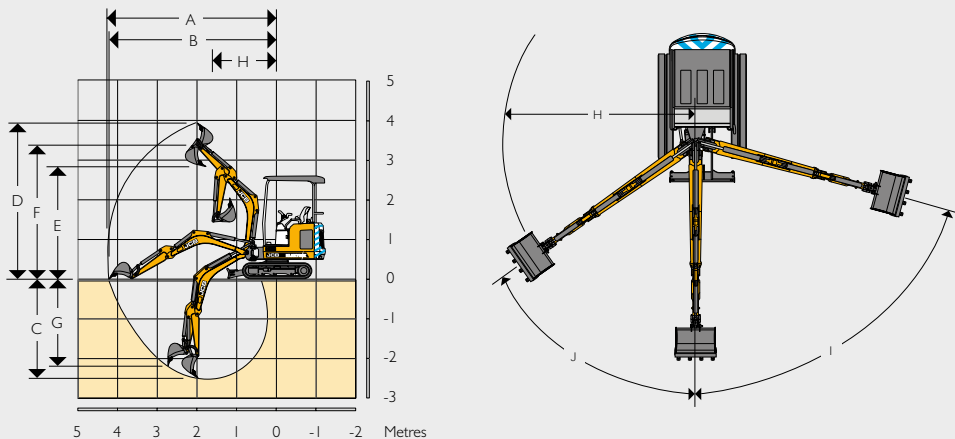

		950mm Dipper	1100mm Dipper	1344mm Gravemaster Dipper	
	Boom length	mm	1800	1800	1800
A	Max. digging reach	mm	3899	4043	4247
B	Max. digging reach on ground	mm	3834	3981	4220
C	Max. digging depth – dozer up	mm	2271	2421	2665
	Max. digging depth – dozer down	mm	2426	2576	2819
D	Max. digging height	mm	3556	3667	3847
E	Max. dump/load-over height	mm	2598	2637	2818
F	Max. height to dipper nose pivot pin	mm	3116	3154	3335
G	Max. vertical wallcut depth	mm	1933	2139	2375
H	Min. front swing radius (no offset)	mm	1488	1517	1565
	Min. front swing radius (fully offset)	mm	1171	1196	1236
I	Boom swing left	degrees	75	75	75
J	Boom swing right	degrees	55	55	55
	Bucket rotation	degrees	201	201	201
	Dipper rotation	degrees	126	126	126
	Bucket tearout (power position)	kN	18	18	18
	Dipper tearout	kN	10.1	9.1	7.9
	Slew speed	rpm	7.9	7.9	7.9

EQUIPMENT

SERVICE AND MAINTENANCE

Beacon ready kit	•
500 hours dig end greasing intervals	•
Grease gun & cartridge	+
Toolkit	+

TRACKS AND UNDERCARRIAGE

230mm short pitch rubber tracks	•
Two speed tracking	•
Retractable undercarriage	•
Extendable dozer blade	•
Heavy duty recoiled tracked tensioners	•
Long dozer blade	+
Auto kick down track motors	•
Auto Kick-up	•

OPERATOR STATION

On-board charger	•
LED worklights	+
Full audio visual warning systems	•
Full control isolation	•
12 volt power socket	•
ISO servo controls	•
Static seat	•
Electro-proportional thumb controlled dual flow auxiliary	+
Dual patterned controls (ISO/SAE changeover)	+
Fabric suspension seat	+
Vinyl suspension seats	+
Fire extinguisher	+
Track lever pedals	+

POWER SOURCE

3 power packs	•
4 power packs	+

HYDRAULICS

Hydraulic slew travel lock	•
Single acting auxiliary circuit	•
Variable displacement pump	•
Straight line travel circuit	•
ORFS hydraulics	•
Quick release auxiliary couplers	•
Double acting auxiliaries	+
Auxiliary vent	•

PROTECTION AND SAFETY

ROPS, TOPS & FOGS certified canopy	•
Internal lockable toolbox	•
Protected boom work light	•
2GO hydraulic isolation	•
Cesar Data Tag (UK ONLY)	•
Disconnect switch	•
Rotating beacon	+
Seat belt engaged green beacon	+
JCB LiveLink	•
Pin pad immobiliser	+
Polycarbonate front screen protection	•
Boom LED worklight guard	+
FOGS guard level I	•
Travel alarm	+

EXTERNAL EQUIPMENT

Charging leads 110V	•
Charging leads 230V	•
Standard dipper (mm)	1100
Dipper options (mm)	950/1344
Tie down points	•
LED beacon	+
Heavy duty kingpost	•
Exterior mirrors	+
GP & bladed bucket range	+
Mechanical quick hitch	+
Hydraulic quick hitch	+
Thumb ready dipper	+

STANDARD •
OPTIONAL +

LIFT CAPACITIES – 230MM RUBBER TRACKS, 1800MM BOOM, 1100MM DIPPER, NO BUCKET. 19C-1E

Load Point	1.5m				2.0m				2.5m				3.0m				3.5m				Capacity at maximum reach				Distance mm				
																													
Height m	Extended kg	Retracted kg	Dozer Up kg	Dozer Down kg	Extended kg	Retracted kg	Dozer Up kg	Dozer Down kg	Extended kg	Retracted kg	Dozer Up kg	Dozer Down kg	Extended kg	Retracted kg	Dozer Up kg	Dozer Down kg	Extended kg	Retracted kg	Dozer Up kg	Dozer Down kg	Extended kg	Retracted kg	Dozer Up kg	Dozer Down kg					
2.5					520*	417	540*	439*	332*	319*	292*	301*													290*	277	270*	327*	2690
2.0					564*	410	586*	476*	334*	321*	297*	311*	373*	219	341	357*									373*	219	341	357*	3000
1.5					615*	396	634*	615*	402*	298	375*	392*	385*	220	356	375*									296	181	281	349*	3300
1.0	689*	430	837	962*	644*	407	613*	646*	494*	286	461*	482*	395*	218	380	398*	274	170	264	336*	274	170	264	336*	274	170	264	336*	3500
0.5	665	417	789	986*	591	359	634	812*	451	273	454	575*	339	209	390	433*	267	165	272	344*	267	165	272	344*	267	165	272	344*	3500
0	780	490	795	958*	566	359	599	769*	424	267	439	552*	257	205	353	438*									306*	170	328*	332*	3400
-0.5	918*	494	902*	920*	673*	359	590	724*	492*	272	432	532*	371*	214	378	392*									308*	191	313*	324*	3250
-1.0	701*	479	705*	788*	551*	350	559*	596*	424*	266	421*	442*	290*	248*	323*	334*									290*	248*	323*	334*	3000
-1.5	512*	476	480*	527*	460*	360	412*	428*																	354*	298	348*	388*	2200

NOISE/ VIBRATION 19C-E

Noise and Vibration	Uncertainty	Measurement conditions
Noise at the operator station (LpA)	68 dB (KpA)	± 1 dB ISO 6396: 2008
Noise emission from the machine (LWA)	87 dB (KWA)	± 1 dB ISO 6395: 1988
Hand Arm Vibration (m/s ²) Tracking duty Low Idle & Excavating duty	≤ 2.5 (K)	* EN ISO 5349-2: 2001
Whole Body Vibration (m/s ²)	0.41 (K)	0.21 ISO 2631-1: 1997

Based upon a test cycle defined in SAE J 1166

* based on 50% uncertainty of measurement

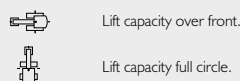

- Notes:**
1. Lifting capacities are based on ISO 10567, that is: 75% of minimum tipping load or 87% of hydraulic lift capacity, whichever is the less. Lifting capacities marked* are based on hydraulic capacity.
 2. Lift capacities assume that the machine is on firm level ground and equipped with an approved lifting point.
 3. A bucket must be fitted when lifting, the weight of this bucket must be deducted from the above lift capacities.
 4. Lift capacities may be limited by local regulations. Please refer to your dealer.



ONE COMPANY, OVER 300 MACHINES.

Your nearest JCB dealer

Electric Mini Excavator 19c-1E

Transport weight: 1787-1827kg Zero Emissions. Lithium-ion Technology.

JCB Sales Limited, Rokester, Staffordshire, United Kingdom ST14 5JP.

Tel: +44 (0)1889 590312 Email: salesinfo@jcb.com

Download the very latest information on this product range at: www.jcb.com

©2009 JCB Sales. All rights reserved. No part of this publication may be reproduced, stored in a retrieval system, or transmitted in any form or by any other means, electronic, mechanical, photocopying or otherwise, without prior permission from JCB Sales. All references in this publication to operating weights, sizes, capacities and other performance measurements are provided for guidance only and may vary dependant upon the exact specification of machine. They should not therefore be relied upon in relation to suitability for a particular application. Guidance and advice should always be sought from your JCB Dealer. JCB reserves the right to change specifications without notice. Illustrations and specifications shown may include optional equipment and accessories. All images are correct at time of print. The JCB logo is a registered trademark of J C Bamford Excavators Ltd.

