

TECHNICAL DATA

TANDEM ROLLERS

BW 90 SC-5, BW 100 SC-5

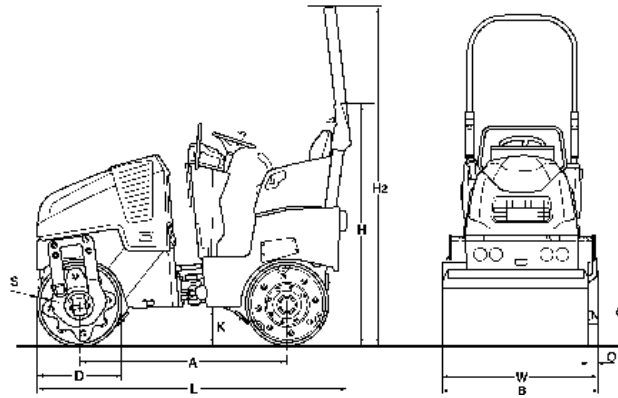



Dimensions in mm

	A	B	C	D	H	H2	K	L	O	S	W
BW 90 SC-5	1483	960	435	580	1627	2304	255	2194	52	12	960
BW 100 SC-5	1483	1060	435	580	1627	2304	255	2194	52	12	1060

Shipping dimensions in m3

BW 90 SC-5
BW 100 SC-5

without ROPS

3,427
3,784

with ROPS

4,853
5,358

Machine type	Compaction output (m3/h) at recommended soil layer thicknesses		
	Gravel, sand	Mixed soil	Silt, clay
BW 90 SC-5	70-120	45-90	35-70
BW 100 SC-5	75-140	50-100	36-70

Machine type	Compaction output (t/h) at different asphalt layer thicknesses		
	2-4 cm	6-8 cm	10-14 cm
BW 90 SC-5	15-30	30-50	40-80
BW 100 SC-5	15-40	35-60	50-90

Technical Data**BOMAG
BW 90 SC-5****BOMAG
BW 100 SC-5****Weights**

Operating weight CECE	kg	1.650	1.700
Average static linear load CECE	kg/cm	9,2	8,5
Grossweight	kg	1.900	1.900

Dimensions

Working width	mm	960	1.060
Track radius, inner	mm	2.000	1.950

Driving Characteristics

Speed	km/h	0- 10,0	0- 10,0
Working speed with vibration	km/h	0- 10,0	0- 10,0
Max. gradeability without/with vibr.	%	40/30	40/30

Drive

Engine manufacturer		Kubota	Kubota
Type		D 902	D 902
Emission stage		Stage V / TIER4f	Stage V / TIER4f
Cooling		water	water
Number of cylinders		3	3
Performance ISO 14396	kW	15,1	15,1
Performance SAE J 1995	hp	20,2	20,2
Speed	min-1	3.000	3.000
Speed adjustment 1	min-1	2.100	2.100
Speed adjustment 2	min-1	3.000	3.000
Electric equipment	V	12	12
Driven drum		front + rear	front + rear

Brakes

Service brake		hydrost.	hydrost.
Parking brake		hydromec.	hydromec.

Steering

Steering system		oscil.artic.	oscil.artic.
Steering method		hydrost.	hydrost.
Steering / oscillating angle +/-	grad	33/8	33/8
Crab walk		0- 50	0- 50

Exciter system

Vibrating drum		front + rear	front + rear
Drive system		hydrost.	hydrost.
Frequency	Hz	42/63	42/63
Amplitude	mm	0,50	0,50
Centrifugal force	kN	8/19	8/19

Sprinkler System

Type of sprinkling		pressure	pressure
--------------------------	--	----------	----------

Capacities

Fuel	l	30,0	30,0
Water	l	100,0	100,0

Technical modifications reserved. Machines may be shown with options.

Standard Equipment

- Side-clearance roller (drum offset 60-100 mm)
- Hydrostatic travel and vibration drive
- Travel drive in series
- 2 scrapers per drum, spring loaded and tiltable
- Pressure sprinkler system with interval switch
- Multi function travel lever
- Multi-function display incl. operating hour meter
- Water level
- Emergency STOP
- Individual control, vibration
- Intelligent Vibration Control (IVC)
- Integrated stowage compartment
- Adjustable operator's seat
- Seat contact switch
- Vandalism protection
- 12V socket
- Working lights front and rear
- Back-up alarm
- Lockable engine hood made of composite material
- Lashing eyes, galvanized
- Single point lifting device

Optional Equipment

- ROPS with safety belt
- * Foldable ROPS incl. seat belt Double
- travel lever
- Seat heating
- BOMAG TELEMATIC
- Theft protection
- Indicator and hazard lights
- Rotary beacon
- Optional lighting on ROPS
- Battery disconnect switch
- Environmentally compliant hydraulic oil
- Special painting
- Edge cutter
- Port for hydraulik breaker
- Backup warning buzzer with broadband technology
- Temperature display

* Standard delivery with CE conformity
(valid within European Union)

