



# TECHNICAL DATA

PNEUMATIC TYRED ROLLERS

BW 28 RH



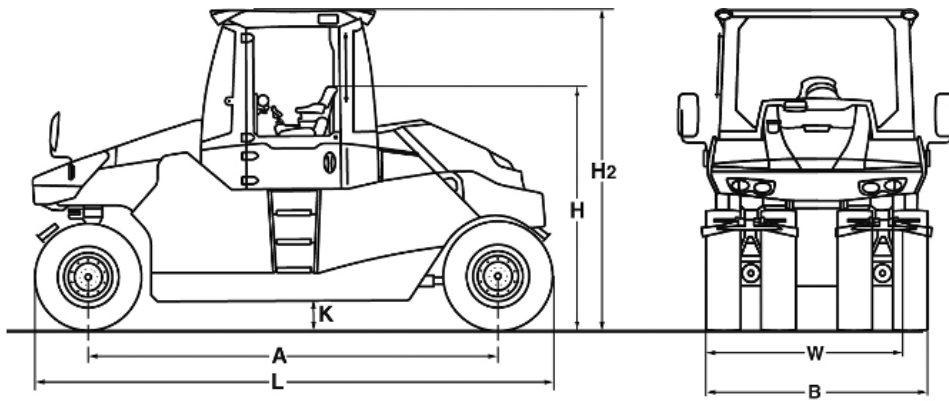

**Dimensions in mm**

	<b>A</b>	<b>B</b>	<b>H</b>	<b>H2</b>	<b>K</b>	<b>L</b>	<b>W</b>
<b>BW 28 RH</b>	3875	2070	2287	3050	280	4945	2042

**Shipping dimensions in m3**

**BW 28 RH**

**without ROPS**

23,410

**with ROPS**

31,220

<b>Machine type</b>	<b>Compaction output (m3/h) (layer thickness) at recommended soil layer thicknesses</b>		
	<b>Silt, clay (0,20 m)</b>	<b>Gravel, sand (0,30 m)</b>	<b>Mixed soil (0,25 m)</b>
BW 28 RH	120-150	120-200	80-180

<b>Machine type</b>	<b>Compaction output (t/h) at different asphalt layer thicknesses</b>		
	<b>2-4 cm</b>	<b>6-8 cm</b>	<b>10-12 cm</b>
BW 28 RH	30-80	60-100	80-150

## Technical Data

## BOMAG BW 28 RH

### Weights

Operating weight CECE w. ROPS-cabin .....	kg	8.600
Grossweight .....	kg	28.000
Max. middle wheel load CECE .....	kg	3.500

### Dimensions

Track radius, inner .....	mm	5.700
---------------------------	----	-------

### Driving Characteristics

Speed (1) .....	km/h	0- 19,0
Max. gradeability (dep. on soil con.) .....	%	27

### Drive

Engine manufacturer .....		Deutz
Type .....		TCD 2012 L04 2V
Emission stage .....		Stage IIIa / TIER3
Cooling .....		Liquid
Number of cylinders .....		4
Performance ISO 14396 .....	kW	92,0
Performance SAE J 1995 .....	hp	123,0
Speed .....	min-1	2.100
Electric equipment .....	V	12
Drive system .....		hydrost.
Driven axles .....		rear

### Tyres

Tyre size .....		11,00-20 18PR
Wheel track overlap .....	mm	32,0

### Brakes

Service brake .....		hydrost.
Parking brake .....		multi disc

### Steering

Steering system .....		2-p. pivoted
Steering method .....		hydrost.
Steering angle +/- .....	grad	30
Oscillation of tyres, front .....	grad	4
Level adjustment .....	mm	100

### Sprinkler System

Type of sprinkling .....		pressure
--------------------------	--	----------

### Capacities

Fuel .....	l	200,0
Water .....	l	340,0
Volume of ballast compartment .....	m3	3,0

Technical modifications reserved. Machines may be shown with options.

### Standard Equipment

- Operator's platform with:
  - Steering wheel
  - Travel lever with multi-functional arm rest
  - Rotable and laterally sliding seat (-70°/+15°)
- Control panel for
  - Speedometer
  - Engine oil pressure
  - Engine temperature
  - Air filter vacuum
  - Charge control
  - Hydraulic oil filter
  - Coolant Level
  - fuel tank capacity
  - Sprinkler system - tank capacity
  - Hour meter
- Warning horn
- Back-up alarm
- BOMAG ECOMODE
- Cold start device
- Service diagnostics tool

### Optional Equipment

- \* ROPS/FOPS with safety belt
- \* ROPS-cabin with heating
- \* ROPS cabin with air conditioning
- Temperature display
- Fire extinguisher
- Rearview camera
- Working lights
- 2 Outside mirrors
- Indicator and hazard lights
- Rotary beacon
- Additional lighting for cabin
- Radio Bluetooth
- Additive spraying system
- Central tyre inflating system
- Scraper brush, spring loaded and tiltable
- Scraper coco mat, spring loaded and tiltable
- Spraying system and scraper
- Thermal aprons
- Profiled tyres
- Wheels MICHELIN 13/80R20
- Wheels DUNLOP 11,00-R20
- Waterproof frame
- Additional weight
  - Max. ballast 10t
  - Max. ballast 10t Flex
  - Max. ballast 12t
  - Max. ballast 12t Flex
  - Max. ballast 16t
  - Max. ballast 16t Flex
  - Max. ballast 18t
  - Max. ballast 20t
  - Max. ballast 24t
  - Max. ballast 28t
- Special painting
- Broadband buzzer
- BOMAG TELEMATIC

\* Standard delivery with CE conformity  
(valid within European Union)#72

