

TECHNICAL DATA

PNEUMATIC TYRED ROLLERS

BW 24 RH, BW 27 RH

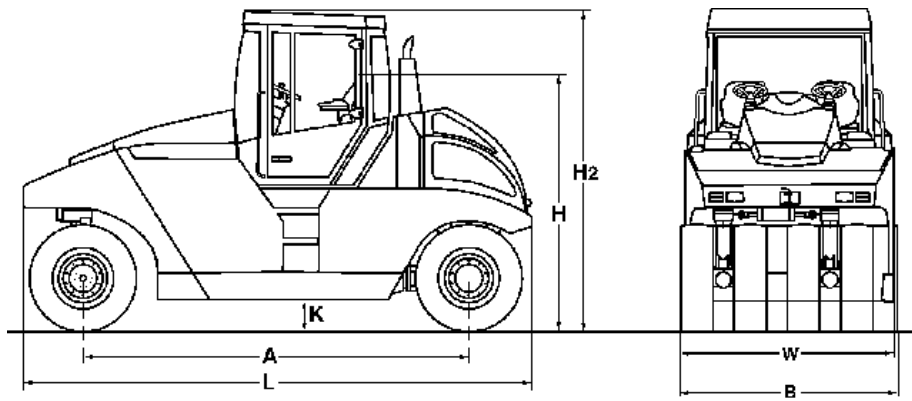



Dimensions in mm

	A	B	H	H2	K	L	W
BW 24 RH	3700	2098	2840	3090	300	4940	2042
BW 27 RH	3700	2098	2840	3090	300	4940	2042

Shipping dimensions in m3

BW 24 RH
BW 27 RH

without ROPS

29,434
29,434

with ROPS

32,025
32,025

Machine type	Compaction output (m3/h) (layer thickness) at recommended soil layer thicknesses		
	Silt, clay (0,20 m)	Gravel, sand (0,30 m)	Mixed soil (0,25 m)
BW 24 RH	100-180	75-150	75-150
BW 27 RH	120-250	120-200	80-180

Machine type	Compaction output (t/h) at different asphalt layer thicknesses		
	2-4 cm	6-8 cm	10-12 cm
BW 24 RH	20-50	50-80	70-130
BW 27 RH	30-80	60-100	80-150

Technical Data

BOMAG BW 24 RH

BOMAG BW 27 RH

Weights

Operating weight CECE w. ROPS-cabin	kg	8.800	13.600
Grossweight	kg	24.000	27.000
Max. middle wheel load CECE	kg	3.000	3.375

Dimensions

Track radius, inner	mm	5.320	5.320
---------------------------	----	-------	-------

Driving Characteristics

Speed (1)	km/h	0- 7,0	0- 7,0
Speed (2)	km/h	0- 10,5	0- 10,5
Speed (3)	km/h	0- 20,0	0- 20,0
Max. gradeability (dep. on soil con.)	%	30	27

Drive

Engine manufacturer		Deutz	Deutz
Type		TCD 2012 L04 2V	TCD 2012 L04 2V
Emission stage		Stage IIIa / TIER3	Stage IIIa / TIER3
Cooling		Liquid	Liquid
Number of cylinders		4	4
Performance ISO 14396	kW	74,9	100,0
Speed	min-1	2.300	2.300
Electric equipment	V	12	12
Drive system			
Driven axles		rear	rear

Tyres

Tyre size		11,00-20 18PR	11,00-20 18PR
Wheel track overlap	mm	42,0	42,0

Brakes

Service brake		pneum./hydr.	pneum./hydr.
Parking brake		multi disc	multi disc

Steering

Steering system		2-p. pivoted	2-p. pivoted
Steering method		hydrost.	hydrost.
Steering angle +/-	grad	30	30
Oscillation of tyres, front	grad	4	4
Level adjustment	mm	100	100

Sprinkler System

Type of sprinkling		pressure	pressure
--------------------------	--	----------	----------

Capacities

Fuel	l	250,0	250,0
Water	l	400,0	400,0
Volume of ballast compartment	m3	3,5	3,5

Technical modifications reserved. Machines may be shown with options.

Standard Equipment

- Operator's platform with:
 - two steering wheels
 - Laterally sliding seat
- Control panel for
 - Hour meter
 - Engine oil pressure
 - Engine temperature
 - Air filter vacuum
 - Charge control
 - Hydraulic oil filter
 - Coolant Level
 - fuel tank capacity
- Lockable anti vandal dashboard protection
- Central tyre inflating system
- 2 Outside mirrors
- Indicator and hazard lights
- Back-up alarm
- Scraper per wheel
- Pressure sprinkler system
- Warning horn

Optional Equipment

- * ROPS/FOPS with safety belt
- * ROPS-cabin with heating
- * ROPS cabin with air conditioning
- Railing
- Sun roof
- Special painting
- Working lights
- Rotary beacon
- Lamp guard
- Rearview camera
- Speedometer
- Radio Bluetooth
- BOMAG TELEMATIC
- Fire extinguisher
- Thermal aprons
- Cold start device
- Edge cutter
- Scraper coco mat, spring loaded and tiltable
- Scraper brush, spring loaded and tiltable
- Environmentally compliant hydraulic oil
- Additional weight
 - Steel 4.800kg (BW24RH)
 - Granulate 5.000kg (BW24RH) Granulate 10.400kg
 - Granulate 13.100kg (BW27RH)
- Waterproof frame
- Wheels DUNLOP 11,00-R20
- Wheels MICHELIN 13/80R20
- Profiled tyres
- Tool kit

* Standard delivery with CE conformity
(valid within European Union)

