



TECHNICAL DATA

SINGLE DRUM ROLLERS

BW 219 DH-5, BW 219 PDH-5



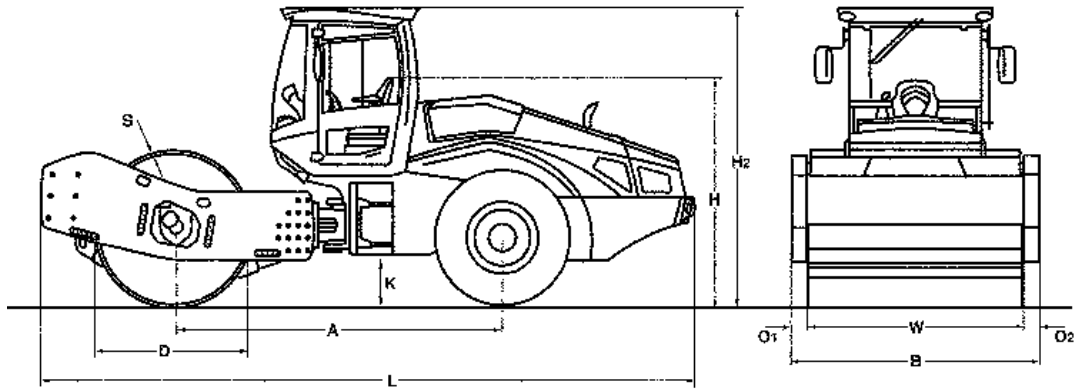

Dimensions in mm

	A	B	D	H	H2	K	L	O1	O2	S	W
BW 219 DH-5	3255	2300	1600	2300	3040	495	6500	85	85	40	2130
BW 219 PDH-5	3255	2300	1500	2295	3034	495	6500	85	85	35	2130

Shipping dimensions in m3

BW 219 DH-5
BW 219 PDH-5

without ROPS

34,385
34,310

with ROPS

45,448
45,358

Machine type	Compaction output (m3/h)			
	Rock fill	Gravel, sand	Mixed soil	Silt, clay
BW 219 DH-5	940-1880	700-1400	560-960	250-500
BW 219 PDH-5	940-1880	700-1400	560-960	280-560

Machine type	Compacted layer thickness (m)			
	Rock fill	Gravel, sand	Mixed soil	Silt, clay
BW 219 DH-5	1,40	1,00	0,70	0,35
BW 219 PDH-5	1,60	1,20	0,80	0,40

Technical Data**BOMAG
BW 219 DH-5****BOMAG
BW 219 PDH-5****Weights**

Grossweight	kg	22.000	21.000
Operating weight CECE w. ROPS-cabin	kg	19.400	20.000
Axle load, drum CECE	kg	12.800	13.200
Axle load, wheels CECE	kg	6.600	6.800
Static linear load CECE	kg/cm	60,1	

Dimensions

Working width	mm	2.130	2.130
Track radius, inner	mm	4.120	4.120

Driving Characteristics

Speed	km/h	0- 10,0	0- 10,0
Max. gradeability without/with vibr.	%	60/57	62/60

Drive

Engine manufacturer		Deutz	Deutz
Type		TCD 2012 L06	TCD 2012 L06
Emission stage		Stage IIIa / TIER3	Stage IIIa / TIER3
Cooling		water	water
Number of cylinders		6	6
Performance ISO 3046	kW	150,0	150,0
Performance SAE J 1995	hp	202,0	202,0
Speed	min-1	2.200	2.200
Fuel		Diesel	Diesel
Electric equipment	V	12	12
Drive system		hydrost.	hydrost.
Drum driven		standard	standard

Drums and Tyres

Number of pad feet			150
Area of one pad foot	cm ²		137
Height of pad feet	mm		100
Tyre size		23.1-26 12PR	23.5-25 16PR

Brakes

Service brake		hydrost.	hydrost.
Parking brake		hydromec.	hydromec.

Steering

Steering system		oscil.artic.	oscil.artic.
Steering method		hydrost.	hydrost.
Steering / oscillating angle +/-	grad	35/12	35/12

Exciter system

Drive system		hydrost.	hydrost.
Frequency	Hz	26/31	26/31
Amplitude	mm	2,10/1,20	1,90/1,00
Centrifugal force	kN	328/266	328/245
Centrifugal force	t	33,5/27,1	33,5/25,0

Capacities

Fuel	l	280,0	280,0
------------	---	-------	-------

Technical modifications reserved. Machines may be shown with options.

Standard Equipment

- BOMAG ECOMODE
- Double pump system for travel drive
- No-Spin differential lock
- Rear axle with twin spring accumulator brakes
- Hydrostatic travel and vibration drive
- Hydrostatic articulated steering
- Articulated joint lock
- Seat with arm rest and adj. for position and height
- Sliding window
- Battery disconnect switch
- Single lever control for travel and vibration
- Warning, information and operation displays with LCD
- Loading mode
- Emergency STOP
- Working lights front / rear
- Back-up alarm
- Noise insulation
- 2 Scrapers
- Warning horn
- Tractor tires (PDH)

Optional Equipment

- ROPS/FOPS cabin with seat belts
 - Sliding window
- Rearview camera
- Air condition
- Radio (Bluetooth)
- Pre start cabin heating
- Comfort package: Adjustable seat and adjustable steering column
- Rotary beacon
- Indicator and hazard lights
- BOMAG ECOSTOP
- ECONOMIZER
- TERRAMETER
- BOMAG TELEMATIC POWER
- BCM 05 Documentation system
- Special painting
- Padfoot segment kit (DH)
- Measuring- and machine data interface for third-party suppliers
- LED Working lights (Cabin)
- Highly wear resistant drum
- Rock tyre

