

# TECHNICAL DATA

SINGLE DRUM ROLLER

BW 218 D-40

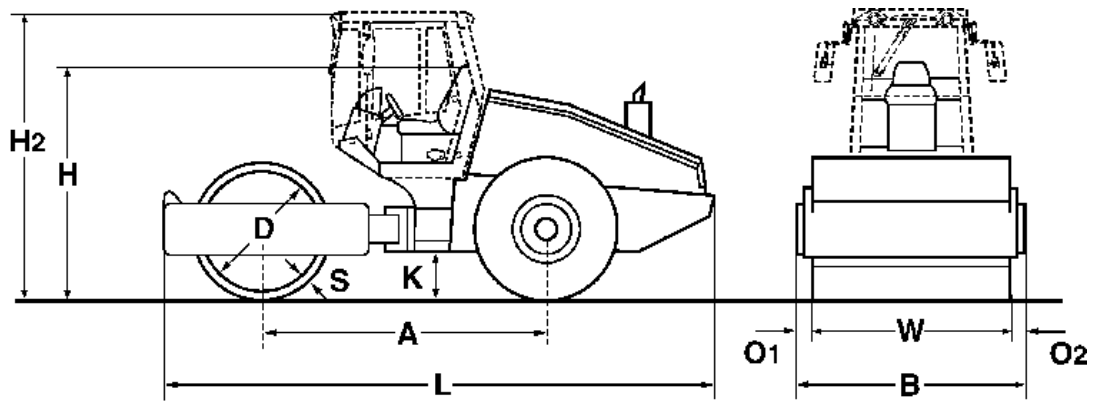



**Dimensions in mm**

	<b>A</b>	<b>B</b>	<b>D</b>	<b>H</b>	<b>H2</b>	<b>K</b>	<b>L</b>	<b>O1</b>	<b>O2</b>	<b>S</b>	<b>W</b>
<b>BW 218 D-40</b>	2960	2480	1500	2268	2985	490	5930	175	175	35	2130

**Shipping dimensions in m3**

**BW 218 D-40**

**without ROPS**

33,354

**with ROPS**

43,899

<b>Machine type</b>	<b>Compaction output (m3/h)</b>			
	<b>Rock fill</b>	<b>Gravel, sand</b>	<b>Mixed soil</b>	<b>Silt, clay</b>
BW 218 D-40	800-1800	550-1100	420-840	260-520

<b>Machine type</b>	<b>Compacted layer thickness (m)</b>			
	<b>Rock fill</b>	<b>Gravel, sand</b>	<b>Mixed soil</b>	<b>Silt, clay</b>
BW 218 D-40	1,30	0,90	0,65	0,30

## Technical Data

## BOMAG BW 218 D-40

### Weights

Grossweight .....	kg	19.100
Max. axle load, drum CECE .....	kg	13.400
Max. axle load, wheels CECE .....	kg	5.700
Operating weight CECE .....	kg	17.200
Axle load, drum CECE .....	kg	12.000
Axle load, wheels CECE .....	kg	5.200
Static linear load CECE .....	kg/cm	56,3
Max. static linear load CECE .....	kg/cm	62,9

### Dimensions

Track radius, inner .....	mm	3.494
---------------------------	----	-------

### Driving Characteristics

Speed (1) .....	km/h	0- 4,0
Speed (2) .....	km/h	0- 5,0
Speed (3) .....	km/h	0- 7,0
Speed (4) .....	km/h	0- 11,0
Max. gradeability without/with vibr. ....	%	48/45

### Drive

Engine manufacturer .....		Deutz
Type .....		BF4M 1013 EC
Emission stage .....		Stage II / TIER2
Cooling .....		water
Number of cylinders .....		4
Performance ISO 3046 .....	kW	114,0
Performance SAE J 1995 .....	hp	153,0
Speed .....	min-1	2.200
Fuel .....		diesel
Electric equipment .....	V	12
Drive system .....		hydrost.
Drum driven .....		standard

### Drums and Tyres

Tyre size .....		23.1-26/12PR
-----------------	--	--------------

### Brakes

Service brake .....		hydrost.
Parking brake .....		hydromec.

### Steering

Steering system .....		oscil.artic.
Steering method .....		hydrost.
Steering / oscillating angle +/- .....	grad	35/12

### Exciter system

Drive system .....		hydrost.
Frequency .....	Hz	30/36
Amplitude .....	mm	1,80/0,90
Centrifugal force .....	kN	275/202
Centrifugal force .....	t	28,1/20,6

### Capacities

Fuel .....	l	250,0
------------	---	-------

Technical modifications reserved. Machines may be shown with options.

### Standard Equipment

- Warning, information and operation displays with round gauge
- Hydrostatic travel and vibration drive
- Hydrostatic articulated steering
- Articulated joint lock
- Rear axle with twin spring accumulator brakes
- No-Spin differential lock
- Warning horn
- Single lever control for travel and vibration
- Scrapers
- Emergency STOP
- Back-up warning system
- Operator seat

### Optional Equipment

- ROPS/FOPS cabin with seat belts
- Working lights front / rear
- ROPS/FOPS with safety belt
- Comfort driver's seat
- Rotary beacon
- Indicator and hazard lights
- Padfoot segment kit
- Contact scrapers
- ECONOMIZER
- BOMAG Evib-Meter (BEM)
- TERRAMETER BTM prof
- BCM 05 Documentation system
- Special painting
- Air condition
- Sun roof
- Warning, information and operation displays
- Radio (Bluetooth)

