

TECHNICAL DATA

SINGLE DRUM ROLLERS

BW 216 D-5, BW 216 PD-5

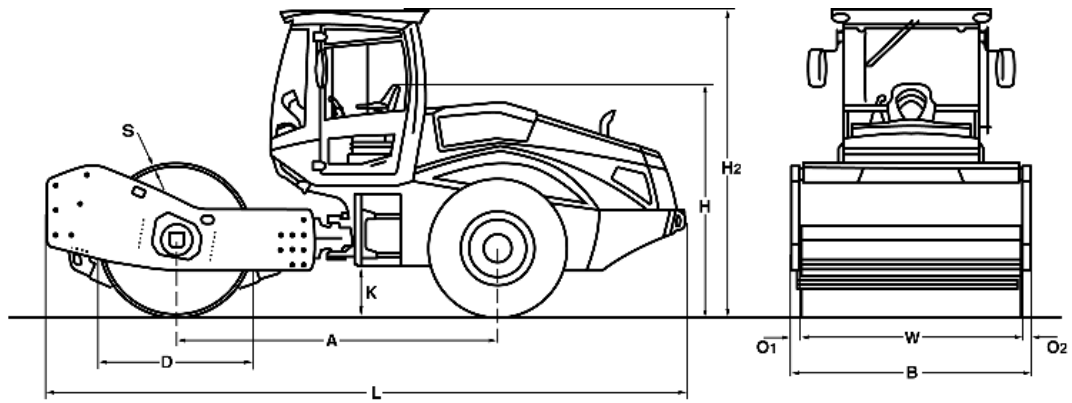



Dimensions in mm

	A	B	D	H	H2	K	L	O1	O2	S	W
BW 216 D-5	3113	2300	1500	2250	3000	490	6220	85	85	30	2130
BW 216 PD-5	3113	2300	1480	2250	2990	490	6220	85	85	25	2130

Shipping dimensions in m3

BW 216 D-5
BW 216 PD-5

without ROPS

32,189
32,189

with ROPS

42,918
42,775

Machine type	Compaction output (m3/h)			
	Rock fill	Gravel, sand	Mixed soil	Silt, clay
BW 216 D-5	650-1200	450-920	340-680	210-420
BW 216 PD-5	650-1200	450-920	340-680	250-500

Machine type	Compacted layer thickness (m)			
	Rock fill	Gravel, sand	Mixed soil	Silt, clay
BW 216 D-5	1,10	0,75	0,55	0,30
BW 216 PD-5	0,90	0,75	0,55	0,55

Technical Data**BOMAG
BW 216 D-5****BOMAG
BW 216 PD-5****Weights**

Grossweight	kg	17.910	17.950
Operating weight CECE w. ROPS-cabin	kg	16.000	17.100
Axle load, drum CECE	kg	10.800	11.900
Axle load, wheels CECE	kg	5.200	5.200
Static linear load CECE	kg/cm	50,7	

Dimensions

Working width	mm	2.130	2.130
Track radius, inner	mm	3.875	3.875

Driving Characteristics

Speed (1)	km/h	0- 3,0	0- 3,0
Speed (2)	km/h	0- 4,0	0- 4,0
Speed (3)	km/h	0- 5,0	0- 5,0
Speed (4)	km/h	0- 10,0	0- 10,0
Max. gradeability without/with vibr.	%	48/45	51/48

Drive

Engine manufacturer		Deutz	Deutz
Type		TCD 2013 L04	TCD 2013 L04
Emission stage		Stage IIIa / TIER3	Stage IIIa / TIER3
Cooling		water	water
Number of cylinders		4	4
Performance ISO 3046	kW	115,0	115,0
Performance SAE J 1995	hp	155,0	155,0
Speed	min-1	2.100	2.100
Fuel		Diesel	Diesel
Electric equipment	V	12	12
Drive system		hydrost.	hydrost.
Drum driven		standard	standard

Drums and Tyres

Number of pad feet			150
Area of one pad foot	cm ²		137
Height of pad feet	mm		100
Tyre size		23.1-26 12PR	23.1-26 12PR

Brakes

Service brake		hydrost.	hydrost.
Parking brake		hydromec.	hydromec.

Steering

Steering system		oscil.artic.	oscil.artic.
Steering method		hydrost.	hydrost.
Steering / oscillating angle +/-	grad	35/12	35/12

Exciter system

Drive system		hydrost.	hydrost.
Frequency	Hz	30/36	30/36
Amplitude	mm	2,10/1,10	1,70/0,90
Centrifugal force	kN	285/220	285/217
Centrifugal force	t	29,1/22,4	29,1/22,1

Capacities

Fuel	l	220,0	220,0
------------	---	-------	-------

Technical modifications reserved. Machines may be shown with options.

Standard Equipment

- BOMAG ECOMODE
- No-Spin differential lock
- Rear axle with twin spring accumulator brakes
- Hydrostatic travel and vibration drive
- Hydrostatic articulated steering
- Articulated joint lock
- Seat with arm rest and adj. for position and height
- Sliding window
- Battery disconnect switch
- Single lever control for travel and vibration
- Warning, information and operation displays with LCD
- Loading mode
- Emergency STOP
- Working lights front / rear
- Back-up alarm
- Noise insulation
- 2 Scrapers
- Warning horn

Optional Equipment

- ROPS/FOPS cabin with seat belts
 - Sliding window
- ROPS/FOPS with safety belt
- Rearview camera
- Air condition
- Radio (Bluetooth)
- Pre start cabin heating
- Comfort package: Adjustable seat and adjustable steering column
- Rotary beacon
- Indicator and hazard lights
- BOMAG ECOSTOP
- ECONOMIZER
- TERRAMETER
- BOMAG TELEMATIC POWER
- BCM 05 Documentation system
- Special painting
- Padfoot segment kit (D)
- Measuring- and machine data interface for third-party suppliers
- LED Working lights (Cabin)
- Highly wear resistant drum

