

# TECHNICAL DATA

SINGLE DRUM ROLLERS

BW 177 D-5, BW 177 DH-5, BW 177 PDH-5

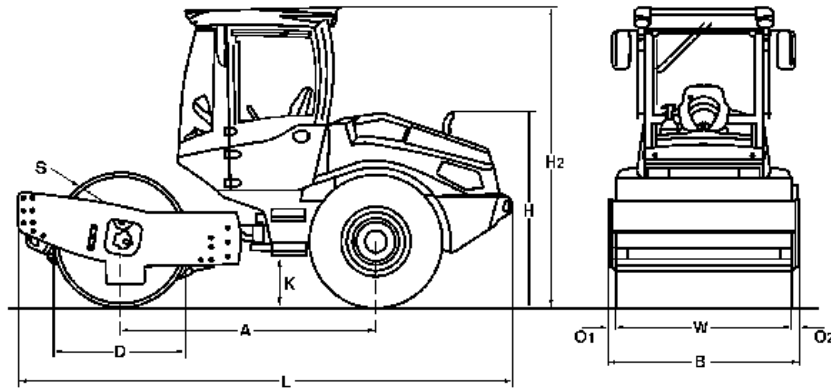



**Dimensions in mm**

	<b>A</b>	<b>B</b>	<b>D</b>	<b>H</b>	<b>H2</b>	<b>K</b>	<b>L</b>	<b>O1</b>	<b>O2</b>	<b>S</b>	<b>W</b>
<b>BW 177 D-5</b>	2350	1820	1228	1655	2800	380	4540	65	65	20	1686
<b>BW 177 DH-5</b>	2350	1820	1228	1655	2800	380	4540	65	65	20	1686
<b>BW 177 PDH-5</b>	2350	1820	1208	1655	2800	380	4540	65	65	15	1686

**Shipping dimensions in m3**

**BW 177 D-5**  
**BW 177 DH-5**  
**BW 177 PDH-5**

**without ROPS**

13,675  
 13,675  
 13,675

**with ROPS**

23,136  
 23,136  
 23,136

<b>Machine type</b>	<b>Compaction output (m3/h)</b>			
	<b>Rock fill</b>	<b>Gravel, sand</b>	<b>Mixed soil</b>	<b>Silt, clay</b>
BW 177 D-5	-	210-420	160-320	70-140
BW 177 DH-5	-	210-420	160-320	70-140
BW 177 PDH-5	-	210-420	160-320	95-190

<b>Machine type</b>	<b>Compacted layer thickness (m)</b>			
	<b>Rock fill</b>	<b>Gravel, sand</b>	<b>Mixed soil</b>	<b>Silt, clay</b>
BW 177 D-5	-	0,45	0,35	0,15
BW 177 DH-5	-	0,45	0,35	0,15
BW 177 PDH-5	-	0,45	0,35	0,20

## Technical Data

## BOMAG BW 177 D-5

## BOMAG BW 177 DH-5

## BOMAG BW 177 PDH-5

### Weights

Grossweight .....	kg	7.800	8.200	7.600
Operating weight CECE w. ROPS-cabin .....	kg	6.600	6.700	6.950
Axle load, drum CECE .....	kg	4.000	4.050	4.300
Axle load, wheels CECE .....	kg	2.600	2.650	2.650
Static linear load CECE .....	kg/cm	23,7	24,0	

### Dimensions

Working width .....	mm	1.686	1.686	1.686
Track radius, inner .....	mm	2.975	2.975	2.975

### Driving Characteristics

Speed (1) .....	km/h	0- 4,5	0- 4,5	0-10
Speed (2) .....	km/h	0- 5,5	0- 5,5	
Speed (3) .....	km/h	0- 7,5	0- 7,5	
Speed (4) .....	km/h	0- 10,5	0- 10,5	
Max. gradeability without/with vibr. ....	%	49/46	61/58	61/58

### Drive

Engine manufacturer .....		Kubota	Kubota	Kubota
Type .....		V 3307 DI-T	V 3307 DI-T	V 3307 DI-T
Emission stage .....		Stage IIIa / TIER3	Stage IIIa / TIER3	Stage IIIa / TIER3
Cooling .....		water	water	water
Number of cylinders .....		4	4	4
Performance ISO 3046 .....	kW	55,4	55,4	55,4
Performance SAE J 1995 .....	hp	75,0	75,0	75,0
Speed .....	min-1	2.400	2.400	2.400
Fuel .....		diesel	diesel	diesel
Electric equipment .....	V	12	12	12
Drive system .....		hydrost.	hydrost.	hydrost.
Drum driven .....		standard	standard	standard

### Drums and Tyres

Tyre size .....		14.9-24/8PR	14.9-24/8PR	14.9-24/8PR
-----------------	--	-------------	-------------	-------------

### Brakes

Service brake .....		hydrost.	hydrost.	hydrost.
Parking brake .....		hydromec.	hydromec.	hydromec.

### Steering

Steering system .....		oscil.artic.	oscil.artic.	oscil.artic.
Steering method .....		hydrost.	hydrost.	hydrost.
Steering / oscillating angle +/- .....	grad	35/12	35/12	35/12

### Exciter system

Drive system .....		hydrost.	hydrost.	hydrost.
Frequency (1) .....	Hz	29	29	29
Frequency (2) .....	Hz	32	32	32
Amplitude .....	mm	1,90/0,80	1,90/0,80	1,75/0,88
Centrifugal force .....	kN	112/74	112/74	112/74
Centrifugal force .....	t	11,4/7,5	11,4/7,5	11,4/7,5

### Capacities

Fuel .....	l	110,0	110,0	110,0
------------	---	-------	-------	-------

Technical modifications reserved. Machines may be shown with options.

### Standard Equipment

- BOMAG ECOMODE
- Double pump system for travel drive (DH/PDH)
- No-Spin differential lock
- Rear axle with twin spring accumulator brakes
- Hydrostatic travel and vibration drive
- Hydrostatic articulated steering
- Articulated joint lock
- Warning, information and operation displays
- Single lever control for travel and vibration
- Emergency STOP
- Warning horn
- Back-up warning system
- Noise insulation
- 2 Contact scrapers Plastic (D/DH)
- 2 Scrapers (PDH)
- Tractor tires (PDH)

### Optional Equipment

- ROPS cabin with seat belts
- ROPS/FOPS with safety belt
- Tractor tires (D/DH)
- Working lights front/rear
- Indicator and hazard lights
- Rotary beacon
- Rearview camera
- Air condition
- Adjustable steering column
- Sliding window
- Radio (Bluetooth)
- BOMAG ECOSTOP
- ECONOMIZER
- TERRAMETER
- Printer for TERRAMETER
- BOMAG TELEMATIC
- BCM 05 Documentation system
- Special painting
- Backup warning buzzer with broadband technology
- Padfoot segment kit (D/DH)
- Dozer blade (DH/PDH)
- Environmentally compliant hydraulic oil
- Measuring- and machine data interface for third-party suppliers
- LED Working lights (Cabin)

