

TECHNICAL DATA

SINGLE DRUM ROLLERS

BW 177 D-5, BW 177 DH-5, BW 177 PDH-5

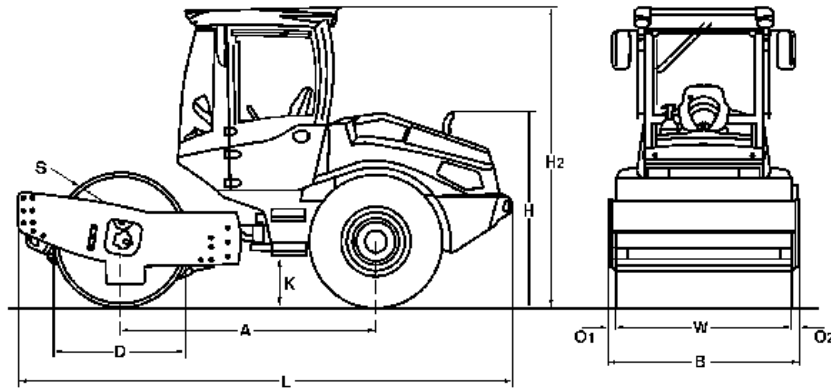



Dimensions in mm

	A	B	D	H	H2	K	L	O1	O2	S	W
BW 177 D-5	2350	1820	1228	1655	2800	380	4540	65	65	20	1686
BW 177 DH-5	2350	1820	1228	1655	2800	380	4540	65	65	20	1686
BW 177 PDH-5	2350	1820	1208	1655	2800	380	4540	65	65	15	1686

Shipping dimensions in m3

BW 177 D-5
BW 177 DH-5
BW 177 PDH-5

without ROPS

13,675
 13,675
 13,675

with ROPS

23,136
 23,136
 23,136

Machine type	Compaction output (m3/h)			
	Rock fill	Gravel, sand	Mixed soil	Silt, clay
BW 177 D-5	-	210-420	160-320	70-140
BW 177 DH-5	-	210-420	160-320	70-140
BW 177 PDH-5	-	210-420	160-320	95-190

Machine type	Compacted layer thickness (m)			
	Rock fill	Gravel, sand	Mixed soil	Silt, clay
BW 177 D-5	-	0,45	0,35	0,15
BW 177 DH-5	-	0,45	0,35	0,15
BW 177 PDH-5	-	0,45	0,35	0,20

Technical Data

BOMAG BW 177 D-5

BOMAG BW 177 DH-5

BOMAG BW 177 PDH-5

Weights

Grossweight	kg	7.800	8.200	7.600
Operating weight CECE w. ROPS-cabin	kg	6.600	6.700	6.950
Axle load, drum CECE	kg	4.000	4.050	4.300
Axle load, wheels CECE	kg	2.600	2.650	2.650
Static linear load CECE	kg/cm	23,7	24,0	

Dimensions

Working width	mm	1.686	1.686	1.686
Track radius, inner	mm	2.975	2.975	2.975

Driving Characteristics

Speed (1)	km/h	0- 4,5	0- 4,5	0-10
Speed (2)	km/h	0- 5,5	0- 5,5	
Speed (3)	km/h	0- 7,5	0- 7,5	
Speed (4)	km/h	0- 10,5	0- 10,5	
Max. gradeability without/with vibr.	%	49/46	61/58	61/58

Drive

Engine manufacturer		Kubota	Kubota	Kubota
Type		V 3307 DI-T	V 3307 DI-T	V 3307 DI-T
Emission stage		Stage IIIa / TIER3	Stage IIIa / TIER3	Stage IIIa / TIER3
Cooling		water	water	water
Number of cylinders		4	4	4
Performance ISO 3046	kW	55,4	55,4	55,4
Performance SAE J 1995	hp	75,0	75,0	75,0
Speed	min-1	2.400	2.400	2.400
Fuel		diesel	diesel	diesel
Electric equipment	V	12	12	12
Drive system		hydrost.	hydrost.	hydrost.
Drum driven		standard	standard	standard

Drums and Tyres

Tyre size		14.9-24/8PR	14.9-24/8PR	14.9-24/8PR
-----------------	--	-------------	-------------	-------------

Brakes

Service brake		hydrost.	hydrost.	hydrost.
Parking brake		hydromec.	hydromec.	hydromec.

Steering

Steering system		oscil.artic.	oscil.artic.	oscil.artic.
Steering method		hydrost.	hydrost.	hydrost.
Steering / oscillating angle +/-	grad	35/12	35/12	35/12

Exciter system

Drive system		hydrost.	hydrost.	hydrost.
Frequency (1)	Hz	29	29	29
Frequency (2)	Hz	32	32	32
Amplitude	mm	1,90/0,80	1,90/0,80	1,75/0,88
Centrifugal force	kN	112/74	112/74	112/74
Centrifugal force	t	11,4/7,5	11,4/7,5	11,4/7,5

Capacities

Fuel	l	110,0	110,0	110,0
------------	---	-------	-------	-------

Technical modifications reserved. Machines may be shown with options.

Standard Equipment

- BOMAG ECOMODE
- Double pump system for travel drive (DH/PDH)
- No-Spin differential lock
- Rear axle with twin spring accumulator brakes
- Hydrostatic travel and vibration drive
- Hydrostatic articulated steering
- Articulated joint lock
- Warning, information and operation displays
- Single lever control for travel and vibration
- Emergency STOP
- Warning horn
- Back-up warning system
- Noise insulation
- 2 Contact scrapers Plastic (D/DH)
- 2 Scrapers (PDH)
- Tractor tires (PDH)

Optional Equipment

- ROPS cabin with seat belts
- ROPS/FOPS with safety belt
- Tractor tires (D/DH)
- Working lights front/rear
- Indicator and hazard lights
- Rotary beacon
- Rearview camera
- Air condition
- Adjustable steering column
- Sliding window
- Radio (Bluetooth)
- BOMAG ECOSTOP
- ECONOMIZER
- TERRAMETER
- Printer for TERRAMETER
- BOMAG TELEMATIC
- BCM 05 Documentation system
- Special painting
- Backup warning buzzer with broadband technology
- Padfoot segment kit (D/DH)
- Dozer blade (DH/PDH)
- Environmentally compliant hydraulic oil
- Measuring- and machine data interface for third-party suppliers
- LED Working lights (Cabin)

