

TECHNICAL DATA

HYBRID - ASPHALT MANAGER 2

BW 174 HYBRID

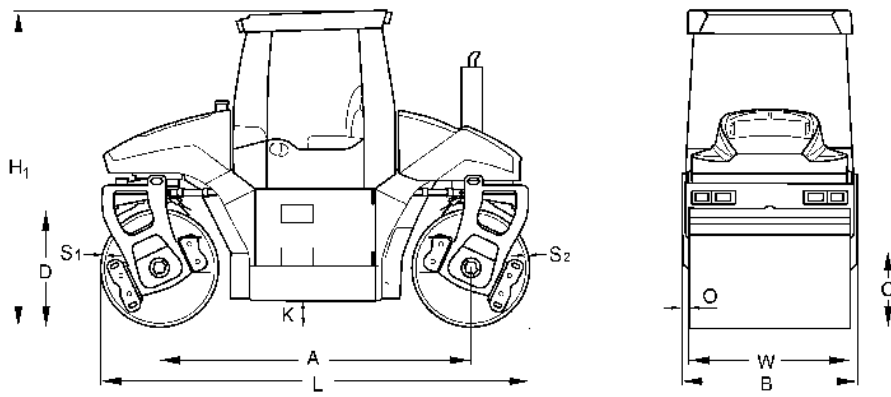



Dimensions in mm

	A	B	C	D	H1	K	L	O	S1	S2	W
BW 174 HYBRID	3200	1826	660	1220	3000	288	4420	73	19	17	1680

Shipping dimensions in m3

BW 174 HYBRID

24,213

Machine type	Compaction output (t/h) at different asphalt layer thicknesses		
	2-4	6-8 cm	10-14 cm
BW 174 HYBRID	60-120	110-210	190-300

Technical Data

BOMAG BW 174 HYBRID

Weights

Operating weight CECE w. ROPS-cabin	kg	9.500
Axle load, front / rear CECE	kg	5.000/4.500
Static linear load, front / rear CECE	kg/cm	29,8/26,8
Grossweight	kg	11.100

Driving Characteristics

Speed (1)	km/h	0- 10,2
-----------------	------	---------

Drive

Engine manufacturer		Kubota
Type		V3307 CR-T
Emission stage		StageV / TIER4f
Exhaust gas aftertreatment		DPF
Cooling		Liquid
Number of cylinders		4
Performance ISO 14396	kW	55,4
Performance SAE J 1995	hp	74,3
Performance HYBRID	kW	20,0
System performance	kW	75,4
Speed	min-1	2.400
Split drum		front + rear

Brakes

Service brake		hydrost.
Parking brake		mech.

Steering

Steering system		2-p. pivoted
Lateral displacement right/left	mm	1.350

Exciter system

Amplitude	mm	0,46/0,20
Frequency	Hz	45/46
Centrifugal force	kN	80/36

Vario system

ASPHALT MANAGER		front
Frequency	Hz	46
Amplitude directed (hor./vert.)	mm	0,73
Centifugal force	kN	146

Capacities

Fuel	l	180,0
Water	l	750,0

Technical modifications reserved. Machines may be shown with options.

Standard Equipment

- ECOMODE
- ASPHALT MANAGER
- Oscillation mode
- Highly wear resistant AM drum
- Plastic water tank under the operator's platform
- Water-saving pressure sprinklers
- 1 Directed exciter, front
- 1 Rotary exciter, rear
- Individual vibration control
- 4 spring-loaded hinged scrapers
- Autom. vibration operation
- Indicator and hazard lights
- ROPS cabin with seat belts + heating
- 2 Outside mirrors
- Steering method/Operator's seat sliding / rotatable
- Steering with comfort control - 5 Steering modes
- Back-up alarm
- Brake release device
- Split drums
- Integrated display(BOP)
- Emergency STOP
- Camera front and rear

Optional Equipment

- Edge cutter
- Rotary beacon
- Special paint
- Environmentally compliant hydraulic oil
- Tool kit
- Precision spreader
- Precision spreader laterally slidable
- Air condition
- Printer for ASPHALT MANAGER
- Radio/Radio preparation
- Lighting for drum edge
- By-pass filter
- Backup warning buzzer with broadband technology
- Additional outside mirrors
- BOMAG TELEMATIC POWER
- BOMAG ECOSTOP
- BOMAP compaction navigation with GPS

