

TECHNICAL DATA

COMBINATION ROLLER

BW 138 AC-5

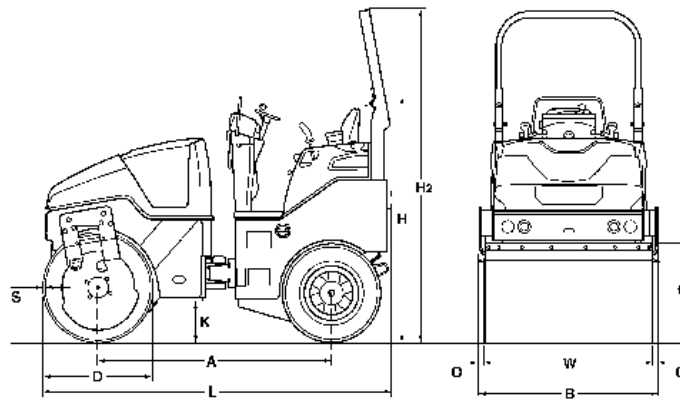



Dimensions in mm

	A	B	C	D	H	H2	K	L	O	S	W
BW 138 AC-5	1900	1468	700	900	1895	2703	340	2840	44	18	1380

Shipping dimensions in m3

BW 138 AC-5

without ROPS

7,900

with ROPS

11,269

Machine type	Compaction output (t/h) at different asphalt layer thicknesses		
	2-4 cm	6-8 cm	10-14 cm
BW 138 AC-5	30-55	50-90	65-115

Technical Data

BOMAG BW 138 AC-5

Weights

Operating weight w. ROPS CECE	kg	4.150
Axle load, drum / wheels CECE	kg	2.150/2.000
Wheel load CECE	kg	500
Static linear load, front CECE	kg/cm	15,6
Grossweight	kg	4.300

Dimensions

Working width	mm	1.380
Track radius, inner	mm	2.616

Driving Characteristics

Max. travel speed	km/h	0- 10,0
Working speed with vibration	km/h	0- 10,0
Max. gradeability without/with vibr.	%	40/30

Drive

Engine manufacturer		Kubota
Type		V 2203
Emission stage		Stage IIIa / TIER4i
Cooling		water
Number of cylinders		4
Performance ISO 14396	kW	33,3
Performance SAE J 1995	hp	44,7
Speed	min-1	2.600
Speed adjustment 1	min-1	2.770
Speed adjustment 2	min-1	2.140
Electric equipment	V	12

Drums and Tyres

Tyre size		10.5/80-16
Number of tyres		4

Brakes

Service brake		hydrost.
Parking brake		hydromec.

Steering

Steering system		oscil.artic.
Steering method		hydrost.
Steering / oscillating angle +/-	grad	32/10
Crab walk		0- 50

Exciter system

Vibrating drum		front
Drive system		hydrost.
Frequency	Hz	50/56
Amplitude	mm	0,50
Centrifugal force	kN	45/57

Capacities

Fuel	l	55,0
Water	l	260,0
Emulsion	l	50,0

Technical modifications reserved. Machines may be shown with options.

Standard Equipment

- Hydrostatic travel and vibration drive
- 2 scrapers per drum, spring loaded and tiltable
- Pressure sprinkler system with interval switch
- Multi function travel lever
- Multi-function display incl. operating hour meter
- Water level
- Electronic fuel gauge
- Emergency STOP
- Individual control, vibration
- Intelligent Vibration Control (IVC)
- Integrated stowage compartment
- Sliding seat incl. double travel lever
- Seat contact switch
- 12V socket
- Working lights front and rear
- Vandalism protection
- Lockable engine hood made of composite material
- Lashing eyes, galvanized
- Single point lifting device
- Back-up alarm

Optional Equipment

- *Foldable ROPS incl. seat belt
- Sun roof, rigid
- Sun roof, foldable with ROPS
- Weather protection for sun roof
- Weather protection cabin
- Seat heating
- ECONOMIZER with asphalt temperature display
- Temperature display
- BOMAG TELEMATIC
- Indicator and hazard lights
- Rotary beacon
- Optional lighting on ROPS
- Lighting for drum edge
- Battery disconnect switch
- Environmentally compliant hydraulic oil
- Theft protection
- Edge cutter
- Gravel scatterer
- Thermal aprons
- Hydraulically adjustable crabwalk (50mm)
- Pointer
- 2. Amplitude:0,2mm
- Backup warning buzzer with broadband technology
- Special painting
- Tool kit

* Standard delivery with CE conformity
(valid within European Union)

