

# TECHNICAL DATA

TANDEM ROLLERS

BW 100 AD-5, BW 120 AD-5

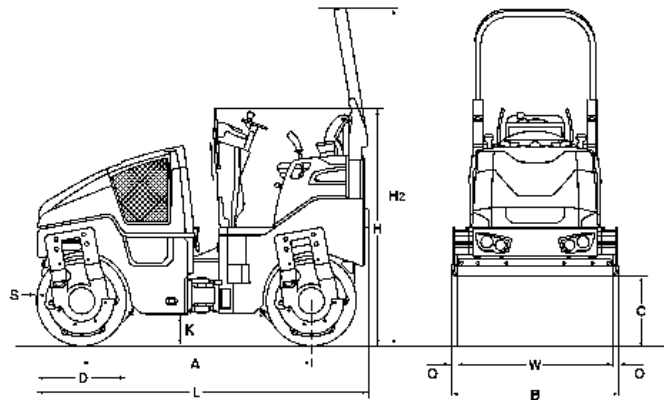



**Dimensions in mm**

	<b>A</b>	<b>B</b>	<b>C</b>	<b>D</b>	<b>H</b>	<b>H2</b>	<b>K</b>	<b>L</b>	<b>O</b>	<b>S</b>	<b>W</b>
<b>BW 100 AD-5</b>	1752	1072	523	700	1808	2568	254	2529	36	13	1000
<b>BW 120 AD-5</b>	1752	1272	523	700	1808	2568	254	2529	36	13	1200

**Shipping dimensions in m3**

**BW 100 AD-5**  
**BW 120 AD-5**

**without ROPS**

4,902  
5,816

**with ROPS**

6,962  
8,261

<b>Machine type</b>	<b>Compaction output (m3/h) at recommended soil layer thicknesses</b>		
	<b>Gravel, sand</b>	<b>Mixed soil</b>	<b>Silt, clay</b>
BW 100 AD-5	80-145	55-105	38-73
BW 120 AD-5	85-170	65-125	43-85

<b>Machine type</b>	<b>Compaction output (t/h) at different asphalt layer thicknesses</b>		
	<b>2-4 cm</b>	<b>6-8 cm</b>	<b>10-12 cm</b>
BW 100 AD-5	15-40	40-60	60-100
BW 120 AD-5	20-45	40-70	70-120

## Technical Data

## BOMAG BW 100 AD-5

## BOMAG BW 120 AD-5

### Weights

Operating weight w. ROPS CECE .....	kg	2.600	2.750
Average static linear load CECE .....	kg/cm	13,0	11,5
Grossweight .....	kg	3.400	3.500

### Dimensions

Working width .....	mm	1.000	1.200
Track radius, inner .....	mm	2.550	2.450

### Driving Characteristics

Speed .....	km/h	0- 10,0	0- 10,0
Working speed with vibration .....	km/h	0- 10,0	0- 10,0
Max. gradeability without/with vibr. ....	%	40/30	40/30

### Drive

Engine manufacturer .....		Kubota	Kubota
Type .....		D1803	D1803
Emission stage .....		Stage V / TIER4f	Stage V / TIER4f
Exhaust gas aftertreatment .....		DPF	DPF
Cooling .....		water	water
Number of cylinders .....		3	3
Performance ISO 14396 .....	kW	24,6	24,6
Performance SAE J 1995 .....	hp	33,0	33,0
Speed .....	min-1	2.600	2.600
Speed adjustment 1 .....	min-1	2.500	2.500
Speed adjustment 2 .....	min-1	2.600	2.600
Electric equipment .....	V	12	12
Driven drum .....		front + rear	front + rear

### Brakes

Service brake .....		hydrost.	hydrost.
Parking brake .....		hydromec.	hydromec.

### Steering

Steering system .....		oscil.artic.	oscil.artic.
Steering method .....		hydrost.	hydrost.
Steering / oscillating angle +/- .....	grad	32/10	32/10
Crab walk .....		0- 50	0- 50

### Exciter system

Vibrating drum .....		front + rear	front + rear
Drive system .....		hydrost.	hydrost.
Frequency .....	Hz	63/67	63/67
Amplitude .....	mm	0,50	0,50
Centrifugal force .....	kN	30/34	36/41

### Sprinkler System

Type of sprinkling .....		pressure	pressure
--------------------------	--	----------	----------

### Capacities

Fuel .....	l	35,0	35,0
Water .....	l	205,0	205,0

Technical modifications reserved. Machines may be shown with options.

### Standard Equipment

- Hydrostatic travel and vibration drive
- Travel drive in series
- 2 scrapers per drum, spring loaded and tiltable
- Pressure sprinkler system with interval switch
- Multi function travel lever
- Multi-function display incl. operating hour meter
- Water level
- Emergency STOP
- Individual control, vibration
- Intelligent Vibration Control (IVC)
- Integrated stowage compartment
- Adjustable operator's seat
- Seat contact switch
- Vandalism protection
- 12V socket
- Working lights front and rear
- Back-up alarm
- Lashing eyes, galvanized
- Single point lifting device
- Lockable engine hood made of composite material

### Optional Equipment

- \* Foldable ROPS incl. seat belt
- Sun roof, foldable with ROPS
- Weather protection for sun roof
- Seat heating
- Sliding seat incl. double travel lever
- ECONOMIZER with asphalt temperature display
- Temperature display
- BOMAG TELEMATIC
- Indicator and hazard lights
- Rotary beacon
- Optional lighting on ROPS
- Lighting for drum edge
- Battery disconnect switch
- Environmentally compliant hydraulic oil
- Theft protection
- Edge cutter-right/left
- Gravel scatterer
- Hydraulically adjustable crabwalk (50mm)
- Pointer
- Special painting
- Backup warning buzzer with broadband technology
- Flow divider

\* Standard delivery with CE conformity  
(valid within European Union)

