

TECHNICAL DATA

COMBINATION ROLLERS

BW 100 AC-5, BW 120 AC-5

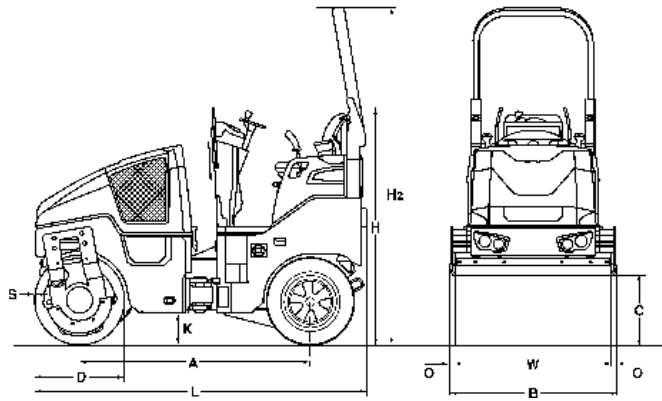



Dimensions in mm

	A	B	C	D	H	H2	K	L	O	S	W
BW 100 AC-5	1752	1072	523	700	1808	2568	254	2529	36	13	1000
BW 120 AC-5	1752	1272	523	700	1808	2568	254	2529	36	13	1200

Shipping dimensions in m3

BW 100 AC-5
BW 120 AC-5

without ROPS

4,902
5,816

with ROPS

6,962
8,261

Machine type	Compaction output (t/h) at different asphalt layer thicknesses		
	2-4 cm	6-8 cm	10-14 cm
BW 100 AC-5	15-35	35-50	45-90
BW 120 AC-5	20-40	40-60	55-105

Technical Data**BOMAG
BW 100 AC-5****BOMAG
BW 120 AC-5****Weights**

Operating weight w. ROPS CECE	kg	2.400	2.450
Axle load, drum / wheels CECE	kg	1.150/1.250	1.200/1.250
Wheel load CECE	kg	313	313
Static linear load, front CECE	kg/cm	12,2	10,0
Grossweight	kg	2.800	2.950

Dimensions

Working width	mm	1.000	1.200
Track radius, inner	mm	2.550	2.450

Driving Characteristics

Speed	km/h	0- 10,0	0- 10,0
Working speed with vibration	km/h	0- 10,0	0- 10,0
Max. gradeability without/with vibr.	%	40/30	40/30

Drive

Engine manufacturer		Kubota	Kubota
Type		D1803	D1803
Emission stage		Stage V / TIER4f	Stage V / TIER4f
Exhaust gas aftertreatment		DPF	DPF
Cooling		water	water
Number of cylinders		3	3
Performance ISO 14396	kW	24,6	24,6
Performance SAE J 1995	hp	33,0	33,0
Speed	min-1	2.600	2.600
Speed adjustment 1	min-1	2.500	2.500
Speed adjustment 2	min-1	2.600	2.600
Electric equipment	V	12	12
Driven drum		standard	standard
Driven wheels		4	4

Drums and Tyres

Tyre size		205/60-15	9.5/65-15
-----------------	--	-----------	-----------

Brakes

Service brake		hydrost.	hydrost.
Parking brake		hydromec.	hydromec.

Steering

Steering system		oscil.artic.	oscil.artic.
Steering method		hydrost.	hydrost.
Steering / oscillating angle +/-	grad	32/10	32/10
Crab walk		0- 50	0- 50

Exciter system

Vibrating drum		front	front
Drive system		hydrost.	hydrost.
Frequency	Hz	63/67	63/67
Amplitude	mm	0,50	0,50
Centrifugal force	kN	30/34	36/41

Sprinkler System

Type of sprinkling		pressure	pressure
--------------------------	--	----------	----------

Capacities

Fuel	l	35,0	35,0
Water	l	160,0	160,0
Emulsion	l	45,0	45,0

Technical modifications reserved. Machines may be shown with options.

Standard Equipment

- Four smooth rear rubber wheels
- Hydrostatic travel and vibration drive
- 2 scrapers per drum, spring loaded and tiltable
- Pressure sprinkler system with interval switch
- Multi function travel lever
- Multi-function display incl. operating hour meter
- Water level
- Emergency STOP
- Intelligent Vibration Control (IVC)
- Integrated stowage compartment
- Adjustable operator's seat
- Seat contact switch
- Vandalism protection
- 12V socket
- Working lights front and rear
- Back-up alarm
- Lockable engine hood made of composite material
- Lashing eyes, galvanized
- Single point lifting device

Optional Equipment

- * Foldable ROPS incl. seat belt
- Sun roof, rigid
- Sun roof, foldable with ROPS
- Weather protection for sun roof
- Seat heating
- Sliding seat incl. double travel lever
- ECONOMIZER with asphalt temperature display
- Temperature display
- BOMAG TELEMATIC
- Indicator and hazard lights
- Rotary beacon
- Optional lighting on ROPS
- Lighting for drum edge
- Battery disconnect switch
- Environmentally compliant hydraulic oil
- Theft protection
- Edge cutter
- Gravel scatterer
- Hydraulically adjustable crabwalk (50mm)
- Pointer
- Special painting
- Backup warning buzzer with broadband technology

* Standard delivery with CE conformity
(valid within European Union)

