

TECHNICAL DATA

COLD PLANER (TIER 3)

BM 500/15, BM 600/15

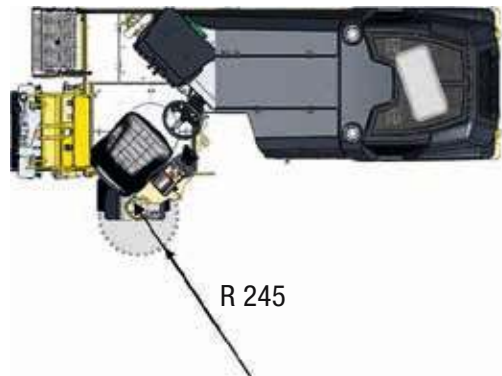

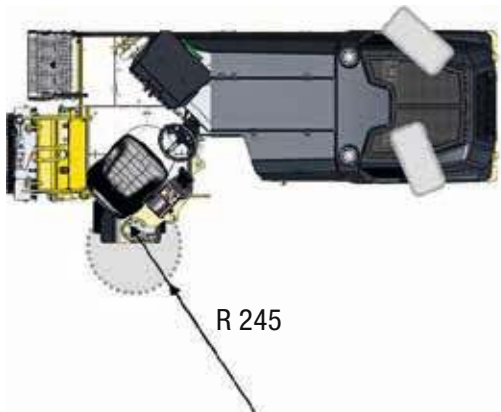
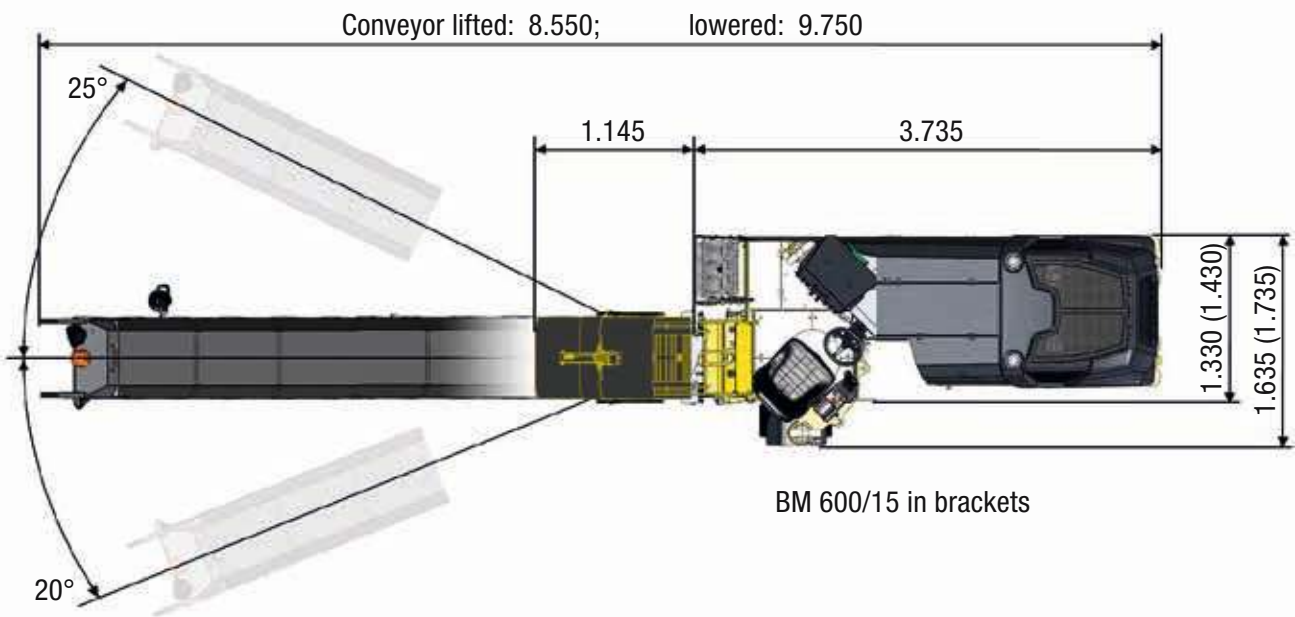
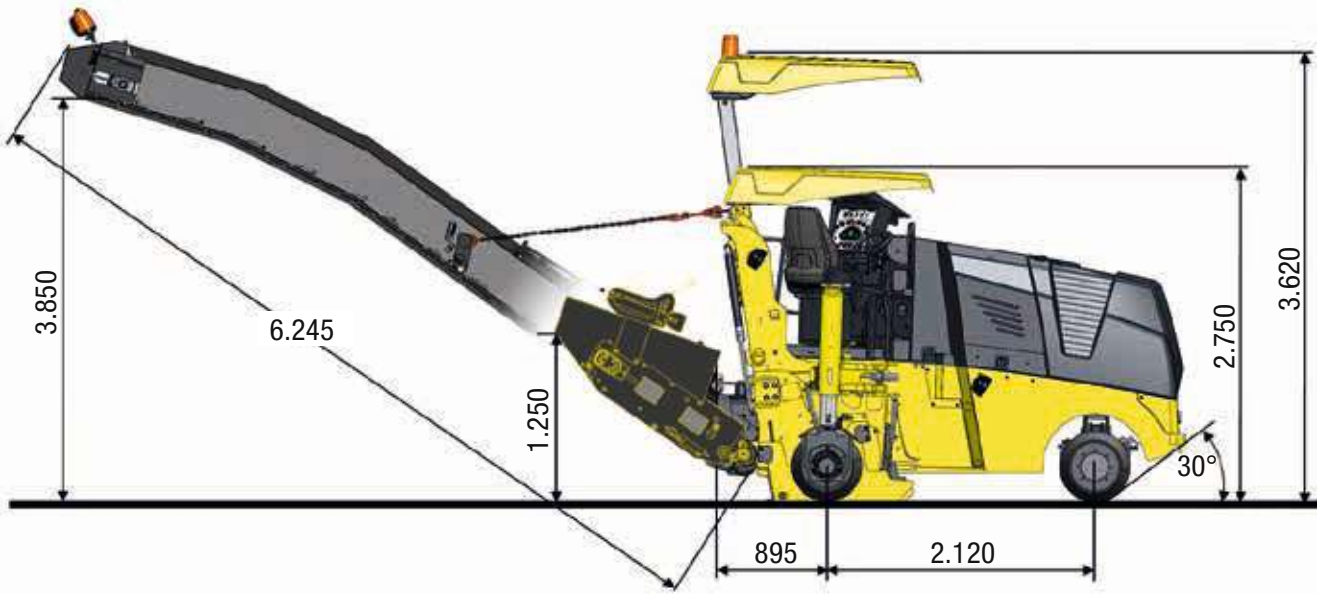

Technical Data

Milling Drum

Milling width max	500	600
Milling depth	0 – 210	0 – 210
Milling line space	15 mm	15
Cutting diameter, tools	700 mm	700
Number of Tools	58	64
Milling drum speed	variable, 115, 130, 145	variable, 115, 130, 145

Drive

Engine Manufacturer	Deutz	Deutz
Type	TCD 2012	TCD 2012
Emission stage	3a / 3	3a / 3
Cooling	Liquid cooled	Liquid cooled
Number of Cylinders / Displacement	4 / 4000	4 / 4000
Power	92 / 125	92 / 125
Engine Speed	2100	2100
Electrical Equipment, Generato	24 / 80	24 / 80
Battery	2 x 12 / 88	2 x 12 / 88

Driving Characteristics

Milling-radius 3-Wheels	245	245
Milling-radius 4-Wheels	245	245
Transport speed	0 – 6	0 – 6
Working speed	0 – 80 variable	0 – 80 variable

Wheels

Type of wheels	Solid rubber	Solid rubber
Rear wheel size (Ø x B)	560 x 254	560 x 254
Front wheel size 3-Wheels (Ø x B)	560 x 254	560 x 254
Front wheel size 4-Wheels (Ø x B)	560 x 203	560 x 203

Capacities

Fuel	230	230
Water	600	600
Hydraulic oil	100	100

Loading-system

Max. operating weight (incl. Options)	400	400
Operating weight, CECE (with conveyor)	85	85
Basic weight (3-Wheels, Drum 500, w/o conveyor).....	3.850	3.850

Weights

Max. operating weight (incl. Options)	8.400	8.500
Operating weight, CECE (with conveyor)	7.600	7.700
Basic weight (3 wheels, Drum 500, w/o conveyor).....	6.700	6.800

Weights, Options

Additional weight 4-Wheel Version	210	210
Additional weight weather protection roof.....	164	164
Additional weight split scraper	50	50
Conveyor, long	520	520
Conveyor, short	120	120

Transport dimensions

Machine, L x B x H (Wheel folded in, w/o Canopy)	3.735 x 1.330 x 2.500	3.735 x 1.430 x 2.500
Machine, L x B x H (with canopy)	3.735 x 1.635 x 2.750	3.735 x 1.735 x 2.750
Conveyor, long, L x B x H	6.247 x 824 x 1.010	6.247 x 824 x 1.010
Conveyor, short, L x B x H	1.200 x 824 x 1.010	1.200 x 824 x 1.010
Max. distance of loading ramps (3-Wheels)	700	700

Technical modifications reserved. Machines may be shown with options.

Standard

Milling technology

- Milling Drum LA15
- 3 Milling-Drum-speeds
- Proportional adjustable water injection
- Automatic water-saving device
- Wear-free, digital Milling-depth-display
- Proportional Milling-depth-adjustment
- Two proportional speeds for Milling-depthadjustment
- Hydraulically operated side-plates
- Hydraulically operated front mouldboard
- Rear mouldboard with adjustable pre-load-pressure
- Right side-plate for fast Drum-exchange
- Automatic load-control
- Automatic distribution of traction

Drive Systems

- 3-Wheel drive
- Right rear wheel foldable from operator place
- Variable transport speed
- Variable operating speed
- Mechanical Drum drive

Operation comfort

- Fully vibration-isolated operator-platform
- Comfort-workstation for sitting operation
- Seat heating
- Ergonomic adjustable operator seat, 45° to slew
- Ergonomic adjustable steering wheel / column
- Height- adjustable arm-rest with integrated ergonomic operation panel
- Self-explanatory, well-arranged dashboard
- Large storage at ground level
- Service- and maintenance-points ergonomic concentrated

Safety & environmental protection

- Whisper-package for noise elimination
- Liquid cooled engine following latest emission rules
- Back-up-alarm
- Two driving lights
- variable working-lights

- Rotary-beacon
- CE-conform safety-package with emergency-stop-switches
- Mirror
- Vandalism protection

Optional

Basic machine

- 4-Wheel-version
- Weather protection roof
- Splitted Scraper
- Port for hydraulik breaker
- Road lights
- Additional working-light, plug in
- Additional working-light, magnet base
- Special colour
- Biodegradable hydraulic oil

Milling technology

- Milling-Drum 600 LA15
- POWER DRUM 500 LA20
- Fine Milling-Drum 600 LA6
- Milling drum 500 LA15
- POWER DRUM 600 LA20
- Fine Milling-Drum 500 LA6
- Milling drum 400 LA14
- Milling drum 300 LA14

Loading-system

- Conveyor, long
- Conveyor, long, hyd. foldable
- Conveyor, short

Automatic Levelling systems

- Levelling Basic, levelling-display, wire-rope sensor, controller (single grade)
- Levelling Advanced 1, additional wire-rope sensor (dual grade)
- Levelling Advanced 2, slope sensor

Others

- Hydraulicbreaker
- Transport trailer

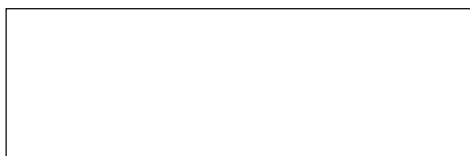

PRE 882 01 010

010317 Sa01

BOMAG
Hellerwald
D-56154 Boppard
Postfach 5162
D-56149 Boppard
Tel. (0)6742 - 1000
Fax (0)6742 - 3090

