

PERFORMANCE DATA

PAVER (TIER 3)

BF 800 P



Greatest durability



Shorter set-up times



Exemplary efficiency

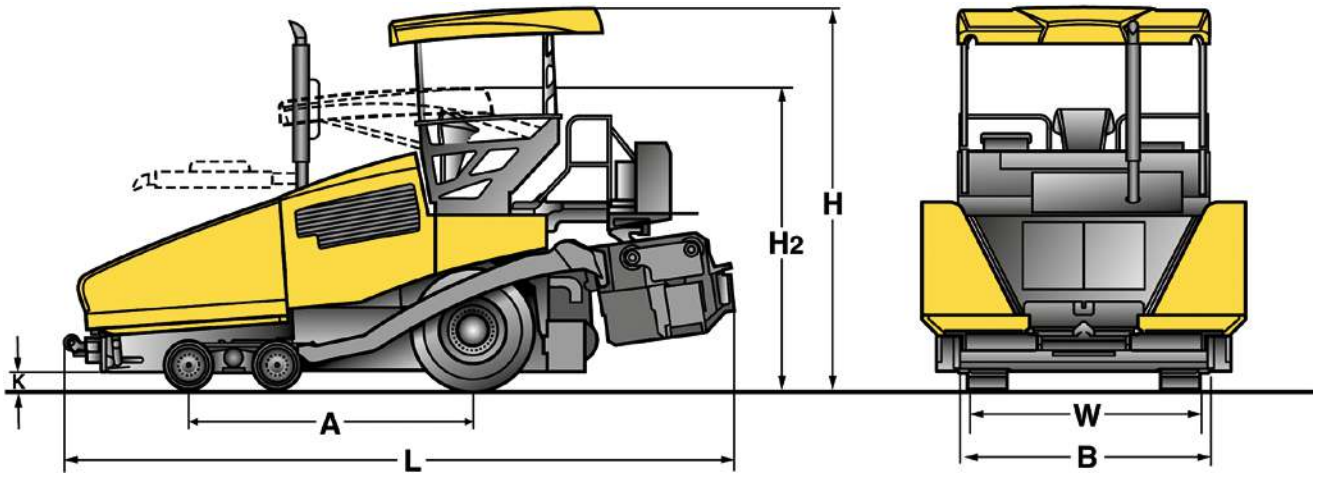

Dimensions in mm

	A	B	H	H ₂	L	W
BF 800 P S 500	3125	2550	3865	3055	6800	2550
BF 800 P S 600	3125	3000	3865	3055	6800	3000

Shipping dimensions in m³

BF 800 P S 500	41,969
BF 800 P S 600	43,423



Save up to 17 % fuel – demand-driven hydraulics – with BOMAG ECOMODE.



Heats up nearly 60 % quicker – unique MAGMALIFE heating system.



Attaching is up to 48 % quicker – thanks to the BOMAG QUICK COUPLING SYSTEM.



The right position in each situation – the comfortable driver's cabin.

Technical Data

Weights

Operating weight CECE kg

Dimensions

Transport length mm
Transport width mm
Transport height mm
Inner track radius mm
Outer track radius mm

Travel characteristics

Travel speed (1) km/h
Travel speed (2) km/h
Working speed (1) m/min
Working speed (2) m/min

Drive

Engine manufacturer
Type
Exhaust classification
Cooling
Number of cylinders
Rated power ISO 3046 kW
Rated speed min⁻¹

Crawler assembly

Rear tyres
-Number
-Type
Front tyres
-Number
-Diameter mm
-Width mm

Hoppe

Capacity m³
Width (wings open) mm
Width (wings closed) mm
Length mm
Filling height (middle) mm

Scraper belt / auger

Quantity
Width mm
Rated speed U/min
Individual control
Reversing operation

Conveyor auger

>Number
->Auger diameter mm
->Rotary speed U/min
->Reversing operation

Screed

Screed type
Basic width retracted mm
Basic width extended mm
Max. working width mm
min. width with reducing skids mm
Mat height mm
Smoothing plate depth mm
Smoothing plate thickness mm
Heating
Crown %
Tamper frequency Hz
Vibration frequency Hz
Basic weight kg

Filling capacities

Fuel l
Hydraulik oil l

Operating/control elements

Number of driver's seats
SideView
LCS System

BOMAG BF 800 P S 500

21000

6800
2550
3055
3900
6500

7
0-15
0-20
0-45

DEUTZ
TCD 2012 L06
Stage III a / TIER 3
Water
6
135
2000

2
445/80 R25

4
500
280

7,2
3320
2250
2010
500

2
400
60
Standard
Standard

2
400
95
Standard

S 500
S 500
2550
5000
9000
1800
300
400
15
Elektric
-2,5 ... +4,5
0-29
20-58
3900

315
160

1
Standard
Standard

BOMAG BF 800 P S 600

21300

6800
3000
3055
3900
6500

7
0-15
0-20
0-45

DEUTZ
TCD 2012 L02
Stage III a / TIER 3
Water
6
135
2000

2
445/80 R25

4
500
280

7,2
3320
2250
2010
500

2
400
60
Standard
Standard

2
400
95
Standard

S 600
S 600
3000
6000
9000
2300
300
400
15
Elektric
-2,5 ... +4,5
0-29
20-58
4200

315
160

1
Standard
Standard

Standard equipment

- SIDEVIEW
- Driver's seat: with swivel and side- shift
- Protection; dashboard
- Hydraulic hinged roof
- Digital display for machine management
- Separate control of hopper wings
- Cleaning kit
- Hydraulic, height adjustable auger
- Track scraper
- L.C.S. Screed relief and traction increase system
- Screed temperature control
- Cast heating elements
- Automatic screed heating
- Hydraulic screed control
- Crown adjustment
- 6 work lights
- Side control of auger/scraper belts
- Tools
- 6 x 6 all wheel drive
- 30 kVA generator
- Socket 2 x 240 volt
- 2 proportionally controlled and reversible wear-resistant cast augers; screw blades separately replaceable
- 2 independent and reversible scraper belts; high- wear resistant plates

Optional equipment

- Hydraulic hopper front flap
- Hydraulic/electric movable platform
- Hydraulic crown adjustment
- Hinged side plates
- Heated side plates
- Side windscreened platform
- Seat warmer
- Asphalt steam extraction
- Biologically degradable hydraulic oil
- Central lubrication system
- L.C.S. half-sided
- Optional paint finish
- S 500 + S 600 extensions:
 - 250 mm
 - 500 mm
 - 750 mm
 - 1250 mm
- Reduction shoe
- Edge shaper 45°/60°
- Light balloon
- Socket 2 x 240 volt
- Levelling systems: Height and cross-slope sensing by means of ultrasonic or mechanical sensors

