

# PERFORMANCE DATA

PAVER (TIER 3)

BF 600 P-2



Greatest durability



Shorter set-up times



Exemplary efficiency

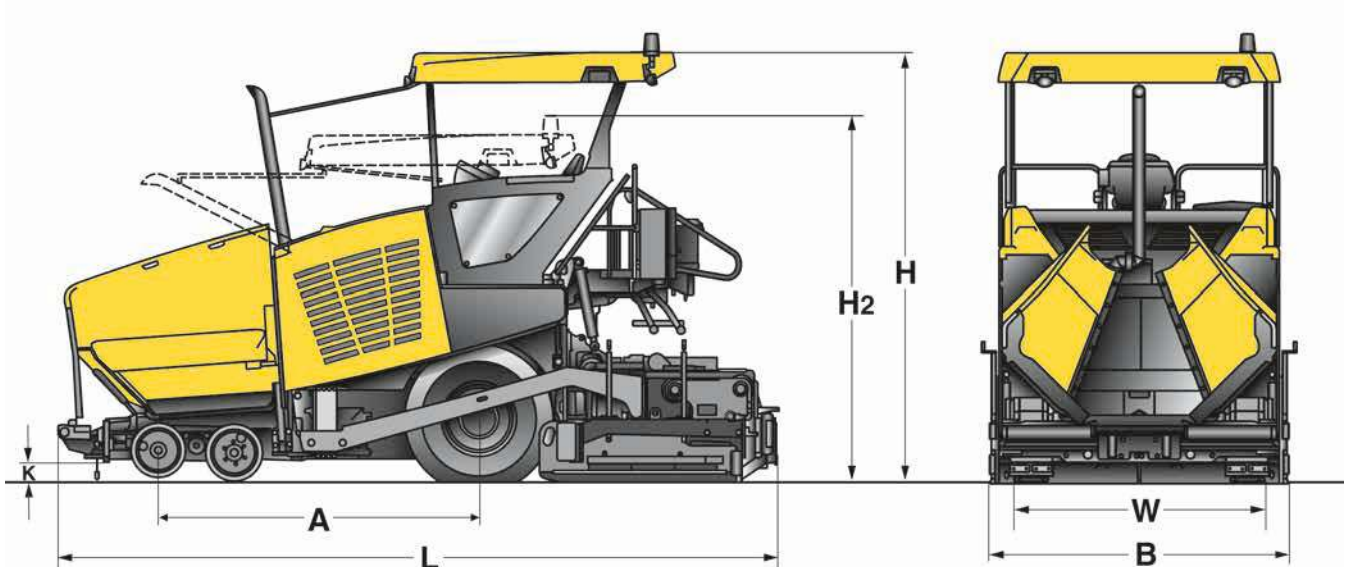

**Dimensions in mm**

	<b>A</b>	<b>B</b>	<b>H</b>	<b>H<sub>2</sub></b>	<b>L</b>	<b>W</b>
<b>BF 600 P-2 S 500</b>	2580	2550	3950	3100	6360	2546
<b>BF 600 P-2 S 600</b>	2580	3000	3950	3100	6360	2546



Save up to 17 % fuel – demand-driven hydraulics – with BOMAG ECOMODE.



Heats up nearly 60 % quicker – unique MAGMALIFE heating system.

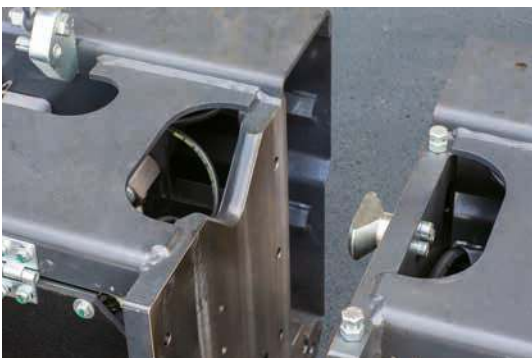

Attaching is up to 48 % quicker – thanks to the BOMAG QUICK COUPLING SYSTEM.



The right position in each situation – the comfortable driver's cabin.

## Technical Data

## BOMAG BF 600 P-2

### Weight CECE

With S 500 screed / with S 600 screed ..... kg 18500 / 18900

### Dimensions

Transport length ..... mm 6360  
Transport width ..... mm 2550 / 3000  
Transport height ..... mm 3100

### Travel characteristics

Travel speed ..... km/h 0-15  
Working speed ..... m/min<sup>-1</sup> 0-45 variable

### Drive

Engine manufacturer ..... Deutz  
Type ..... TCD 2012 L06  
Emission stage ..... Stage III a / TIER 3  
Cooling ..... liquid  
Number of cylinders / Displacement ..... cm<sup>3</sup> 6 / 6067  
Rated power ..... kW / HP 128 / 174

### Undercarriage

Rear tyres / Number ..... 2  
Type ..... 445/80 R 25  
Front tyres / Number ..... 4  
Diameter ..... mm 500  
Width ..... mm 280

### Hopper

Capacity ..... m<sup>3</sup> 7,0  
Width (wings open) ..... mm 3330  
Width (wings closed) ..... mm 2270  
Length ..... mm 1800  
Filling height (middle) ..... mm 515

### Conveyor

Number ..... 2  
Rotary speed ..... U/min 64  
Individual control ..... Standard  
Reversing operation ..... Standard

### Auger

Number ..... mm 2  
Auger diameter ..... mm 350  
Rotary speed ..... U/min 117  
Reversing operation ..... Standard

### Screed

Basic width retracted ..... mm 2500 / 3000  
Basic width extended ..... mm 5000 / 6000  
Min. width with reduction skids ..... mm 1800 / 2300  
Mat thickness ..... mm 300  
Screed plate depth ..... mm 400  
Screed plate thickness ..... mm 15  
Heating ..... electric  
Crown ..... % -2,5 ... +4,5  
Tmaper frequency ..... Hz 0-29  
Vibration frequency ..... Hz 20-58  
Basic weight ..... kg 3900 / 4200  
Max. working width ..... mm 7500

### Filling capacities

Fuel ..... l 285  
Hydraulic oil ..... l 160

## Standard Equipment

### Operator compartment

- SIDEVIEW
- Driver's seat: with swivel and side-shift
- Dashboard protection
- Hydraulic hinged roof
- Digital display for machine Management

### Tractor

- ECOMODE
- Separate control of hopper wings
- Cleaning kit
- Hydraulic, height adjustable auger
- Track scraper
- 2 proportionally controlled and reversible wear-resistant cast augers; screw blades separately replaceable
- 2 independent and reversible scraper belts; high-wear resistant plates
- 4 x 6 wheel drive

### Screed

- L.C.S. Screed relief and traction increase system
- Screed temperature control
- MAGMALIFE Aluminium heating plates
- MAGMALIFE Automatic screed heating
- Hydraulic screed lock
- Crown adjustment
- Side control of auger/scraper belts

### Other

- Tools
- 8 work lights
- 20/30 kVA generator
- Socket 2 x 240 volt

## Optional Equipment

### Operator compartment

- Hydraulic/electric movable SIDEVIEW platform
- Side windscreened platform
- Seat warmer
- Asphalt steam extraction

### Tractor

- Central lubrication system
- Optional paint finish
- Biologically degradable hydraulic oil
- 6 x 6 all-wheel drive
- Hydraulic hopper front flap
- Hydraulic suspended and dampened push rollers
- Road homologation kit

### Screed

- Hydraulic crown adjustment
- Hinged side plates
- Heated side plates
- L.C.S. half-sided
- S 500 + S 600 extensions:
  - 250 mm
  - 500 mm
  - 750 mm
  - 1250 mm
- Reduction shoes
- Edge shaper 45°/60°

### Levelling systems

- Height and cross-slope sensing by means of ultrasonic or mechanical sensors

### Other

- Fleet management BOMAG TELEMATIC
- Moon-light balloon

