

TECHNICAL DATA

SOIL COMPACTOR

BC 473 EB-3

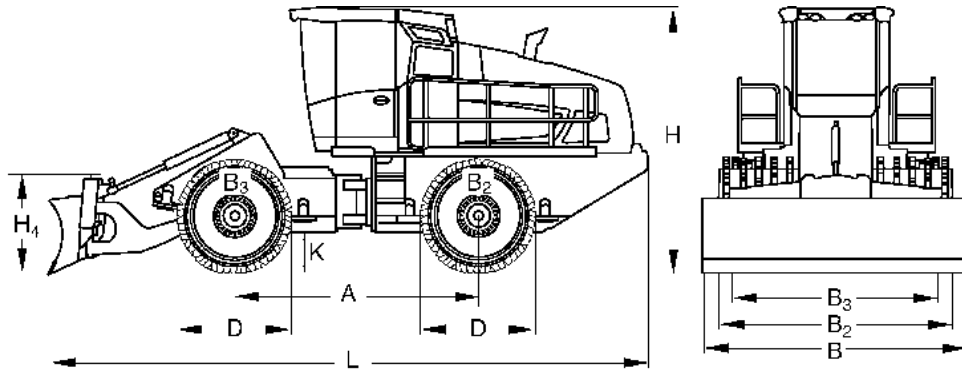



Dimensions in mm

	A	B	B2	B3	D	H	H4	K	L
BC 473 EB-3	3500	3600	3560	3335	1580	3820	1027	600	8990

Shipping dimensions in m3

BC 473 EB-3	123,630
--------------------	---------

Technical Data

BOMAG BC 473 EB-3

Weights

Grossweight	kg	26.500
Operating weight CECE	kg	25.700
Axle load, front CECE	kg	12.750
Axle load, rear CECE	kg	12.950

Driving Characteristics

Speed (1), forward	km/h	0- 4,5
Speed (1), reverse	km/h	0- 4,5
Speed (2), forward	km/h	0- 12,0
Speed (2), reverse	km/h	0- 12,0
Max. gradeability (dep. on soil con.)	%	100
Max. pushing force	kN	281

Drive

Engine manufacturer		Deutz
Type		TCD 2013 L06 4V
Emission stage		Stage IIIa / TIER3
Cooling		Liquid
Number of cylinders		6
Performance ISO 9249	kW	227,0
Performance SAE J 1349	hp	304,0
Speed	min-1	2.200
Travel system		hydrost.
Operating voltage	V	24

Compaction Wheels

Width, front	mm	1.125
Width, rear	mm	1.125
Outer diameter (front)	mm	1.580
Outer diameter (rear)	mm	1.580
Number of teeth/cutters, front		60
Number of teeth/cutters, rear		60
Compaction coverage per side	mm	1.238

Brakes

Service brake		hydrost.
Parking brake		hydromec.

Steering

Steering system		oscil.artic.
Steering method		hydraulic
Steering angle +/-	grad	35
Oscillating angle +/-	grad	15
Track radius, inner	mm	3.762

Dozer Blade

Height adjustment over ground level	mm	1.200
Height adjustment below ground level	mm	120

Capacities

Fuel	l	375,0
Hydraulic oil	l	260,0

Technical modifications reserved. Machines may be shown with options.

Standard Equipment

- Electronic engine management
- Electronic monitoring module with engine shut-down
- Dry air filter
- Multi fuel filter system
- Fuel bleeding pump
- Four wheel drives, hydraulic differential lock in the front and rear (Twin pump drive)
- Wear control in hydraulic circuit
- Oscillating articulated joint between front and rear frames
- Adjustable scrapers in front of and behind each wheel
- All drive components well protected by the closed frame pan
- ROPS/FOPS
- Noise insulated cab with automatic heating – air conditioning
- Vibration insulated cab suspension
- Safety glass cabin window panes
- Sun visor
- Hinged window left
- Windscreen wiper / washer front
- Outside rear mirrors
- Activated carbon filter
- High air intake
- Air suspended seat
- Control unit for dozer blade and travel direction control beside the driver's seat
- Joystick steering
- Display instruments
- Lockable cabin and engine hood
- 24 V electrics
- Generator 80 A
- Battery disconnecting switch
- Working lights, 4 front / 2 rear
- Audible backup alarm
- Warning horn
- Access steps right / left
- Towing eyes front / rear
- Heated rear screens
- Reversible fan
- Working platform
- Rearview camera

Optional Equipment

- Premium compaction wheels with highly wear resistant teeth
- Blade 3600 mm / tilting mechanism
- Central lubrication system
- CD-Radio
- Pre start cabin heating
- Rotary beacon
- Fire extinguisher
- Special painting
- Environmentally compliant hydraulic oil
- Electrical anti-theft system with numerical code
- Protective ventilation system (Pre-installation)
- Tool kit
- Protective grille for cabin
- Climatronic
- Tachograph
- LED Working head lights
- TELEMATIC POWER

