

# **T/C-5600** **TEXTURE/CURE MACHINE**



*The Worldwide Leader in Concrete Paving Technology*

# T/C-5600 Texture/Cure Machine

## Easy Transport

- Tracks turn 90 degrees for transport.
- The spray bar and work bridge assembly folds up hydraulically for transport.
- Transport height is 10.4 feet (3.17 m) with the exhaust pipe removed.



The four-track T/C-5600 texture/cure machine can turn its tracks 90 degrees to drive onto a trailer for transport.

## Walking End Car

The T/C-5600 texture/cure machine features a new walking end car with cure tank. Frame sections can be added or removed by turning the tracks 90 degrees, and walking the end car with attached cure tank to the required width. The walkway and railway telescope with the walking end car.

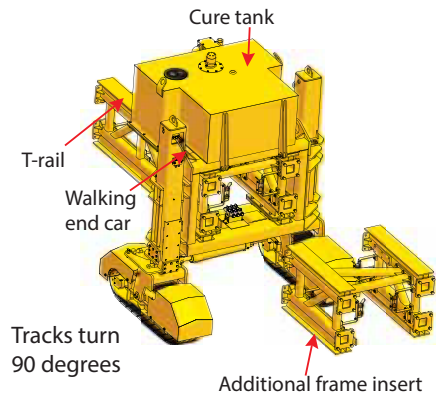

The walking end car allows the T/C-5600 to turn its tracks and walk the end car in or out for additional end sections to be added or removed.



The T/C-5600 texture/cure machine features GOMACO's G+ control system with forward and reverse steering and grade control. It can be sensed off stringline or other methods from our sensor library. This provides ease of operation and accuracy while texturing and curing.



The GOMACO T/C-5600 texture/cure machine has the structural integrity to apply texture and cure up to 56 feet (17.1 m) wide.

## New Tracer Texture Control For Transverse Tining

- The transverse tining undercarriage has 12 inches (305 mm) of hydraulic vertical height adjustment and is controlled using a sonic sensor, allowing the tining carriage to trace the slab elevation.
- A sonic sensor traces the slab with the transverse travel of the tining broom. The depth of tining is controlled by the hydraulic height adjustment on the broom carriage. This provides accurate tining depth, eliminates rail adjustments, and eliminates the need for a power transition adjuster (PTA).
- Proximity switches and an encoder are used to control the tining carriage end points and travel distance across the slab via user inputs to the G+ controller.
- The T/C-5600 is capable of advancing forward the length of the transverse tining broom with the auto-advance feature.
- The Tracer Texture Control also works on transition adjustments with longitudinal tining.
- The longitudinal tining operation has a sonic sensor mounted over the center of the slab. The center assembly has 10 inches (254 mm) of hydraulic vertical height adjustment for crowning. The ends of the hinged longitudinal tining framework are used to set the tining member to grade.

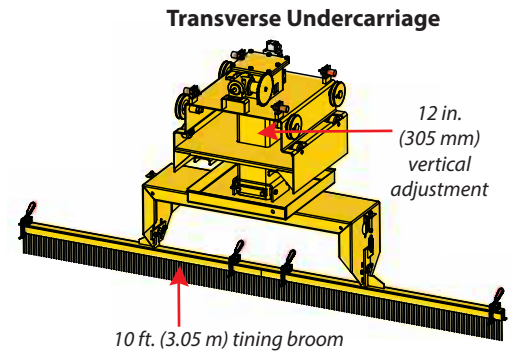

## Single Pass Transverse Texture/Cure Option

The tining broom and spray bar are each seven feet (2.13 m) long, so tining and curing can be done in a single pass or in two separate operations. The single pass transverse texture/cure option for the machine has a spray bar mounted to the tining carriage. The spray bar folds in 90 degrees for transport.

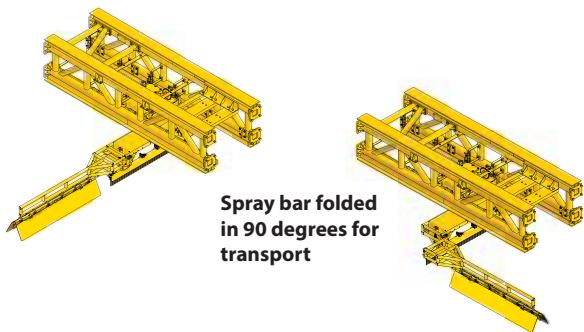

The spray bar, mounted to the back of the work bridge, provides full coverage of the concrete pavement.

### Side view in transport mode

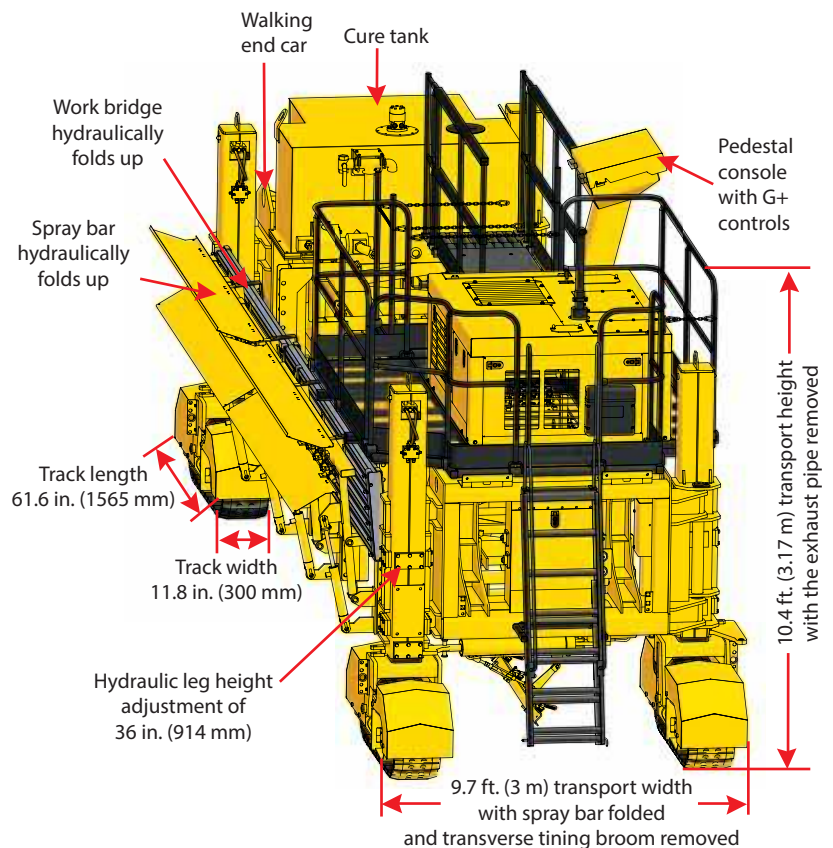



One pass texturing and curing is possible with the four-track T/C-5600 texture/cure machine. On this project, steering and grade were referenced off the new slab with sonar sensors for grade and a standard steer sensor wand on the edge of the slab.

## Specifications

### ENGINE

Consult for options available.

### SERVICE CAPACITIES

**Fuel tank reservoir:** 30 gal. (113.6 L).

**Hydraulic oil reservoir:** 50 gal. (189.3 L).

### AUTOMATIC CONTROL SYSTEM

**Type:** Electronic-over-hydraulic.

**Controls:** GOMACO's exclusive G+® control system features forward and reverse steering and grade control. It is sensed off stringline or other methods from our sensor library. This provides ease of operation and accuracy in texturing and curing.

### TRACTION SYSTEM

**Track length:** 61.6 in. (1565 mm).

**Track width:** 11.8 in. (300 mm).

**Track speed:** Low-range track speed up to 36 fpm (11 mpm) and a high-range track speed up to 95 fpm (29 mpm).

**Hydraulic leg height adjustment:** 36 in. (914 mm).

**Ground pressure:** 19.34 psi (1.36 kgf/cm<sup>2</sup>) based on 36,920 lb. (16,747 kg) machine weight.

### TRANSPORT DIMENSIONS

**Transport width:** 9.7 ft. (3 m) with spray bar folded and transverse tining broom removed.

**Transport height:** 10.4 ft. (3.17 m) with the exhaust pipe removed.

### -- DESIGNED FOR SAFETY --

The T/C-5600 is carefully designed to give years of dependable and safe service. The emergency stop buttons are on the operator's console, and on corners of the machine, which are easily accessible from the ground level. Another safety feature is a backup alarm, which is designed to alert personnel around the machine when the tracks are set to operate in reverse. Other safety features include track guards, warning decals, an operator's manual, and a safety manual.

**GOMACO CORPORATION RECOMMENDS THE IMPLEMENTATION OF ALL SAFETY PROCEDURES.**



*The Worldwide Leader in Concrete Paving Technology*

#### Worldwide Headquarters

GOMACO Corporation  
PO Box 151  
Ida Grove, IA USA 51445  
Ph: 712-364-3347  
www.gomaco.com  
E-mail: info@gomaco.com

#### European Headquarters

GOMACO International Ltd.  
Units 14 & 15  
Avenue One, Station Lane  
Witney, Oxon, OX28 4XZ, United Kingdom  
Ph: 44-1993-705100  
E-mail: pavinguk@gomaco.com

### WEIGHT

**Operating weight:** 36,920 lbs. (16,747 kg) based on the machine texturing/curing a 24 ft. (7.32 m) slab.

### FRAME INSERTS

Insert lengths available are 4 ft. (1.22 m), 8 ft. (2.44 m), and 12 ft. (3.66 m).

### CURE SYSTEM

**Spraying pump (max):** 29.18 gpm (110.44 lpm).

**Cure tank reservoir:** 300 gal. (1135.6 L).

### TEXTURING ASSEMBLY

**1.) Longitudinal tining.**

**2.) Transverse tining:** 10 ft. (3.05 m) wide with 5 in. (127 mm) long wire tines spaced to meet specification requirements.

**3.) Single pass transverse texture/cure option:** 7 ft. (2.13 m) transverse tining bar with a 7 ft. (2.13 m) folding spray bar.

**Optional:** Additional wire tine texturing members are built to specifications.

### OPTIONS AVAILABLE

Burlap drag.  
Burlap water system.  
Poly roller.  
Dual cure spray bar.  
Skewed tining.  
Longitudinal tining.  
Transverse spray bar.  
G+ sensor library.

Cover Photo: CL-081604-D18

Manufactured under one or more of the following U.S. or foreign patents: 5,924,817; 5,941,659; 6,099,204; 6,450,048; CA2,211,331; 7,044,680; 7,284,472; 7,517,171; 7,845,878; 7,850,395; CA2,864,902; CA2,591,177; 8,855,967; 8,682,622; 9,051,696; 9,180,909; 9,200,414; 9,404,228; 9,428,869; 9,458,581; 9,464,716; 9,541,195; and patents pending.

GOMACO and G+ are registered trademarks of GOMACO Corporation.

GOMACO Corporation reserves the right to make improvements in design, material, and/or changes in specifications at any time without notice and without incurring any obligation related to such changes. Performance data is based on averages and may vary from machine to machine.

Printed in U.S.A. © 2017 (1 GC) GOMACO Corp.



GOMACO Corporation's Quality Management System Is ISO 9001 Certified By The American Systems Registrar.

Quality Policy: We Shall Meet Or Exceed Our Customers' Expectations.

